

THIN

PN

STRIPPIT STYLE

ENGLISH

MATE[®]
M
**PRECISION
TECHNOLOGIES**
RESPECT • SUPPORT • INSPIRE



Thin Turret Tooling

FOR STRIPPIT STYLE PUNCH PRESSES



Headquartered in Anoka, Minnesota, in a 300,000 sq. ft. (28,000m²) state-of-the-art facility.



OVER FIVE DECADES OF EXCELLENCE

Founded in 1962, Mate is a world-class manufacturer of superior solutions for the metal cutting and metal forming industries. We manufacture workholding systems, CNC punch press tooling, and offer a complete line of press brake tooling and laser consumables. Mate products and services are available worldwide, fully supported by more than 80 dealers in every industrialized country.



PERSONAL, RESPECTFUL RELATIONSHIPS

Mate does business with people, not companies. Our connection to you is personal. Mate's team of manufacturing and metalworking professionals knows what you go through. We know what it's like to compete for that next job, manage deadlines or even need a rescue. With Mate you have a partner that respects your knowledge and is dedicated to helping you succeed.

YOUR GO-TO SOURCE

Serving our customers is at the core of who we are. In your plant or on the phone, we're up for whatever metalworking challenges you face. Your Mate representatives are experts who know from experience what happens on the shop floor and provide our legendary in-field support. They speak your language, fully capable of helping you improve processes and solve problems. Mate customer service is ready to assist with fast quotes, guiding your order on to our top-notch machinists and shipping pros.



GET INSPIRED!

With our vast knowledge and broad product range we inspire innovative thinking. Our customer's projects can be seen around the world: from unique building façades thought to be impossible to make, to a new way to add strength to thin material. The possibilities are endless, so think big, bold and beyond.

WE'VE GOT YOU COVERED

Dedicated to quality in every aspect of our business, Mate offers an extensive standard product line that can be delivered with same day or next day service. All Mate products are backed with our industry leading 100% customer satisfaction guarantee.



MATE'S MISSION AND PROMISE TO YOU:

Mate's mission is to personally **Respect, Support** and **Inspire** metalworking professionals around the world with high-quality products and services for factory productivity.



Features and Benefits	4-5
Strippit Style Tooling Features and Benefits	4
Mate DuraSteel™ High Performance Tool Steel	4
Coatings	5
Mate Slug Free® Dies	5
1-1/4" Tooling	6-8
1/2" Snap-Apart Tooling for 1-1/4" Station	6
5/8" Drop-In Tooling for 1-1/4" Station	7
1-1/4" Full Body Tooling for 1-1/4" Station	8
Accessories – 1-1/4" and 3-1/2"	9
1-1/4" and 3-1/2" Station Alignment Tools	
1-1/4" and 3-1/2" Station Punch and Die Adapters	
Mate Xcel™ Tooling	10-16
1-1/4" Station	10-11
2" Station	12-13
3-1/2" Station	14-15
Fully Guided Tooling System for 3-1/2" Station	16
Xcel™ 3-1/2" Guide Accessories	16
Cluster Assemblies	17
Maintenance Fixture	18
Multi Tool Systems	19
Xcel™ 3 and 8-Station Multi Tools	
MTG™ Tooling	
Forming Units	20

Special Applications	21-31
Cluster	22
Card Guide	22
Countersink	23
Emboss - Beaded	23
Cold Forged	24
Emboss - Formed	24
Extrusion-Tapping	25
Hinge	25
Knockout	26
Louwer	26
Lance and Form	27
Stamping-Alpha Numeric	27
Stamping-V-Line Inscription	28
Threadform	28
Mate Rollerball®	29
Mate Sheetmarker®	29
Mate SnapLock™	30
Mate HexLock™	30
Mate EasySnap™	31
Mate 19" Racking Cluster	31
Mate Special Shapes	32-33
Technical Data	34-37
Total Die Clearance and Hole Quality	34
Calculating Punching Force	35
Angle Setting Details	36
Add-Ons for Rounds and Shapes	36
Dimensional and Punch Grind Life Data	37

FEATURE AND BENEFITS

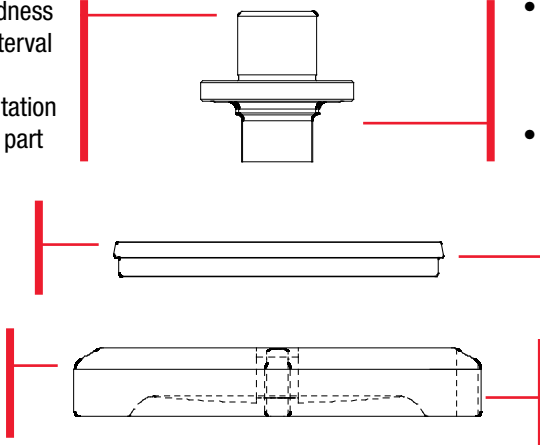
- DuraSteel™ with superior hardness and toughness for extended interval between regrinds.
 - Hardened key for precise orientation of punches for improved piece part quality.
 - Smooth rounded edges to eliminate sheet marking and improve piece part quality.
 - Slug Free® die geometry eliminates slug pulling to improve piece part quality and increase tool life.
- 
- 1/4 degree back taper and near polished punch flanks to reduce friction, eliminate galling, and maximize punch life.
 - Maxima® coating available for extreme applications.
 - Ground for superior angularity and concentricity.
 - Highly wear-resistant tool steel provides optimum balance between hardness and toughness, for extended life.

MATE DURASTEEL™ HIGH PERFORMANCE TOOL STEEL

Mate DuraSteel™ is an air hardened tool steel designed specifically for use in high performance tooling systems.

A combination of the chemical composition of Mate DuraSteel and the closely controlled manufacturing process results in an upgrade to conventional High Chrome D2 tool steel. It offers better wear resistance, greater toughness, better compressive strength, and higher attainable hardness.

Mate DuraSteel is a high quality tool steel which has many advantages when compared to alternative tool steels commonly available. These advantages include:

Superior Wear Resistance—Mate DuraSteel offers superior resistance to adhesive- and abrasive-wear to maximize the interval between regrinds.

- Increased Vanadium carbides—harder wearing than chromium carbides for greater resistance to abrasive-wear.
- Increased Tungsten carbides—harder wearing and offer better red hardness; increased resistance to high temperatures may anneal or damage the material.
- Higher hardness—increased alloy content results in higher effective hardness for better wear resistance.

Increased Toughness—the chemical composition and heat treatment processes used with Mate DuraSteel make it tougher than conventional tool steels in impact strength tests. The inclusion of tungsten and vanadium allows the carbon content to be reduced, which increases the toughness.

Better Value—Customer trials have shown that tools manufactured in Mate DuraSteel last 100% longer between regrinds than tools manufactured using conventional tool steels. By increasing the interval between regrinds, the tooling lasts longer and punches many more holes before needing to be replaced.

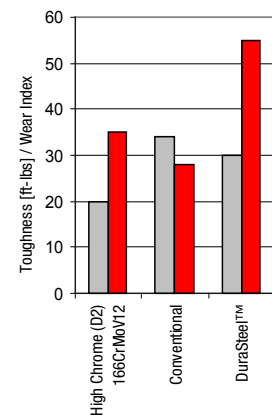

□ Toughness ■ Relative Wear Resistance

DuraSteel™ Chemical Composition	
Carbon	1.10%
Chromium	7.50%
Vanadium	2.40%
Tungsten	1.15%
Molybdenum	1.60%

- Toughness: Charpy C-Notch impact strength test.
- Relative Wear Resistance: 10x Cross cylinder adhesive wear test.
- Based upon steel manufacturers data.

[Dimensions in Inches (mm)]

MAXIMA® COATING

Maxima is a premium tool steel coating that has been specially formulated for punch press tooling applications. Maxima is a multilayer Zirconium Titanium Nitride (ZrTiN) coating that is hard, wear resistant, and lubricious. It acts as a barrier between the punch and the sheet metal being punched and, because of its exceptional lubricity, greatly improves stripping.

Maxima is an extremely hard, wear resistant, slippery material which reduces the friction that occurs during the stripping portion of the punching cycle, it is particularly good for abrasive tooling applications.



SUPERMAX™ COATING

Mate SuperMax™ is a **proprietary** next generation coating specifically formulated for punch press tooling. A hard, wear resistant, and lubricious coating, SuperMax acts as a barrier between the punch and sheet metal to greatly improve stripping. In customer testing, SuperMax outperforms currently available premium coatings by 2 to 8 times, depending on the application.

Applied using the very latest nano-layer technology, SuperMax's harder, denser film greatly increases wear resistance and has a much lower friction coefficient of about 20%. Lower friction means less heat build-up, less galling and longer tool life. SuperMax is particularly good for adhesive wear tooling applications. The lubricity is also beneficial when punching sharp cornered shapes with a 90 degree or smaller angle.



SuperMax is recommended for applications such as 3000 and 5000 series aluminum, cold rolled, galvanized and stainless steels; even pre-painted, vinyl coated and fiberglass materials.

SuperMax can be applied to M4PM™, M2, and Durasteel™ punches.

Since SuperMax is a semi-transparent coating, we've made it easy to identify by including a protective green tip.*

MATE SLUG FREE® DIES

Mate Slug Free® dies eliminate slug pulling. Slug pulling is a condition where the slug returns to the top of the sheet during the stripping portion of the punching cycle. The slug comes between the punch and the top of the sheet on the next cycle. This causes damage to the piece part and the tooling. Slug Free dies eliminate this problem.

The Slug Free die has been designed with an opening that has a constriction point below the surface so the slug cannot return once it passes this point. Once the slug is separated from the punch, it is free to fall away from the punching area. Slug pulling is eliminated.

- Eliminate slug pulling
- Reduce tool breakage
- Improve tool life
- Increase quality

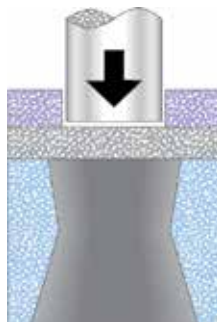

Material held securely by stripper before punch makes contact.

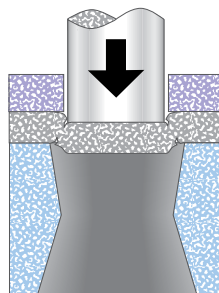

Punch penetrates the material. Slug fractures away from sheet.

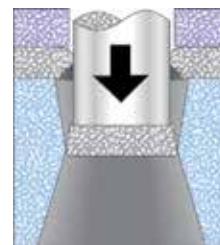

Pressure point constricts slug. Punch stroke bottoms out as slug squeezes past pressure point.

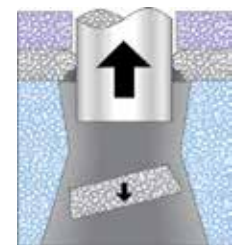

Punch retracts and slug is free to fall down and away through exit taper of the Slug Free® die.

[Dimensions in Inches (mm)]

Upper Assembly

Round punch assembly
Shaped punch assembly

(Includes punch head, spring, spring retainer, guide, standard shape punch, stripper and stripper retaining ring.)

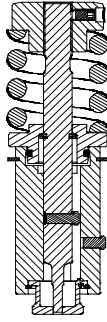
**Punch**

Round* **PCSA0A**
Shape* **PCSA_A**
Ring** **SRI0002**
(2 req'd) **SRI0002**
Maxima® Coating

DuraSteel™

each

Hardware

Punch Head **MATE00393**
Spring **MATE0007**
Spring Retainer (with O-ring) **MATE0011**
Support Ring **SRI0003**
Guide—Round **MATE0014**
Guide—Shape **MATE0016**
Stripper Retaining Ring **SRI0004**

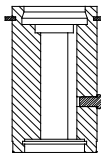
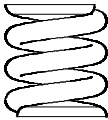
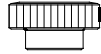
**Stripper**

Round* **SCSA0A**
Shape* **SCSA_A**

**Slug Free® Die**

Round **DASB00**
Shape **DASB_0**
Shim Pack **MSAB**

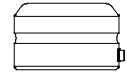

* Can be used with existing 1/2" drop-in style holders.

** Snap ring supplied with each punch. Must be removed for use in Strippit style guide assembly.

Urethane Slug Ejector—3.00mm	URE40002 (12 minimum)
Urethane Slug Ejector—6.00mm	URE40010 (12 minimum)
2.5mm Hex Wrench	MIS98896
Medium India Oil Stone	STO29807
Snap Ring Pliers	MIS61129
Punch head set screw (cone point)	SSS00005

[Dimensions in Inches (mm)]

Upper Assembly

Round punch assembly
Shaped punch assembly

(Includes punch head, guide and canister assembly, standard shape punch, and stripper)

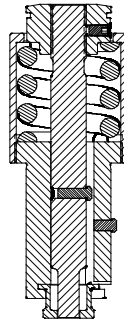

Punch

Round **PDSX0A**
Shape **PDSX_A**

DuraSteel™



Stripper

Round **SDSX0A**
Shape **SDSX_A**
Round** **SESX0A**
Shape** **SESX_A**



Hardware

Punch Head **MATE00386**
Canister and Guide Assembly
MATE00391

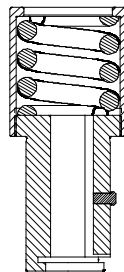

Slug Free® Die

Round **DASB00**
Shape **DASB_0**
Shim Pack **MSAB**

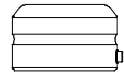

Urethane Slug Ejector—3.00mm	URE40002 (12 minimum)
Urethane Slug Ejector—6.00mm	URE40010 (12 minimum)
2.5mm Hex Wrench	MIS98896
Medium India Oil Stone	STO29807
Punch head set screw (cone point)	SSS00005

STANDARD SHAPES (NUMBERING INDICATES SHAPE CODE):



[Dimensions in Inches (mm)]

Upper Assembly

Round punch assembly
Shaped punch assembly

(Includes punch head, spring, spring retainer, standard shape punch, and stripper)

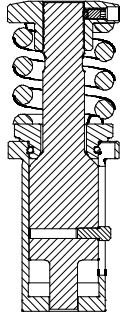

Punch

Round **PBSB0A**
Shape **PBSB_A**

DuraSteel™

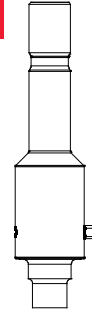

Stripper

Round **SBSB0A**
Shape **SBSB_A**

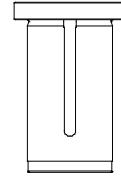

Hardware

Punch Head **MATE00388**
Spring **MATE00007**
Spring Retainer
(with O-Ring) **MATE00003**
Punch Shim **MATE00333**

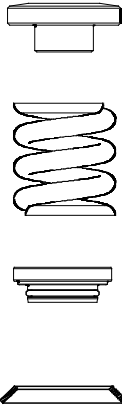

Slug Free® Die

Round **DASB00**
Shape **DASB_0**
Shim Pack **MSAB**

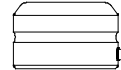

Urethane Slug Ejector—3.00mm	URE40002 (12 minimum)
Urethane Slug Ejector—6.00mm	URE40010 (12 minimum)
2.5mm Hex Wrench	MIS98896
Medium India Oil Stone	STO29807
Punch head set screw (cone point)	SSS00005

[Dimensions in Inches (mm)]

Mate manufactures a comprehensive range of alignment tools to enable you to restore the alignment of each station with the same or better precision as the initial machine installation. Superior piece part quality, extended machine life, and longer tool life is achieved when the upper and lower turrets of a punch press are precisely aligned.

ALIGNMENT PACKAGE	MATE00736
COMPRISES:	
A 1-1/4" Station Upper Alignment Tool	VSALTB
B 1-1/4" Station Lower Alignment Tool	MAALTB
C 3-1/2" Station Upper Alignment Tool	VSALTD
D 3-1/2" Station Lower Alignment Tool	MSALTD
E Handle	VNALT
F Alignment Bar	NLUBAR
G Adjustment Rod	NALROD

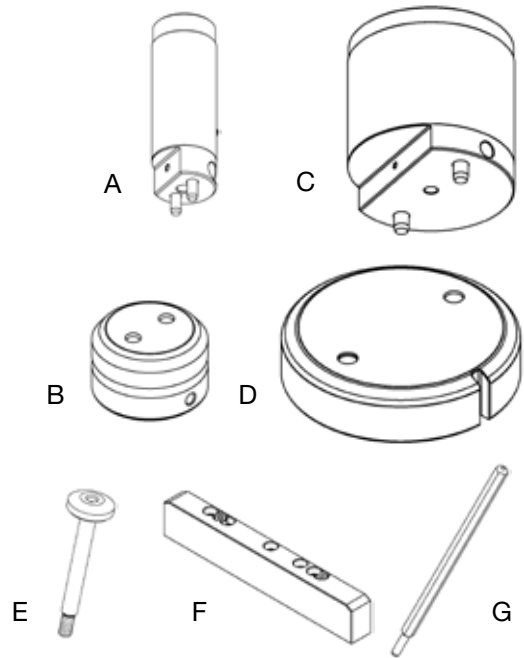

PUNCH AND DIE ADAPTERS 1-1/4" AND 3-1/2" STATION

Mate manufactures a comprehensive range of adapters to allow 1-1/4" tooling to be used in 3-1/2" stations in a variety of Strippit Style Tooled punch presses.

Machine Style	Station Configuration	Piercing or Forming	Upper Adapter Assembly	Lower Adapter Assembly
Strippit Style*	Standard	Both	MATE00740	MATE00742
Finn-Power**	Upforming	Piercing	MATE00740	MATE00744
		Forming	MATE00740	MATE00742
Finn-Power**	Upforming Auto-Index	Piercing	MATE00740	MATE00746
		Forming	N/A***	N/A***

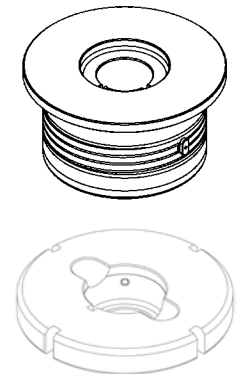

- * includes all punch presses that are configured to accept Strippit Style Tooling, including Finn-Power punch presses that do not have the upforming forming capability in the 3-1/2" station. Not compatible with Strippit "R" series machines.
- ** Finn-Power machines with upforming capability in the 3-1/2" D stations use different lower adapters as shown in the table above.
- *** The use of a 3-1/2" D station forming assembly is recommended when forming in a Finn-Power punch press with upforming capability in the Auto-Index station.

[Dimensions in Inches (mm)]

Introducing the Mate Xcel™ Tooling System for 1-1/4" Thin Turret Stations. Mate Xcel is a high performance tooling system with features designed to reduce set-up time, improve piece part quality and maximize productivity.

Features include:

MATE XCEL™ CANISTER ASSEMBLY

- Quick punch length adjustment without disassembly for rapid tool change and maximum productivity.
- Push button mechanism allows punch length adjustment in 0.008(0.20) increments for quick and precise tool set-up.
- Superior engagement between canister and guide to prevent length adjustment during punching cycle.
- Self-contained, pre-loaded spring pack for consistent stripping pressure and reliable operation.
- Maximum punch-head surface area for positive contact with machine ram for reliable operation.
- Compatible with existing tooling inventory for added economy and maximum flexibility.

PUNCH

- DuraSteel™ with superior hardness and toughness for extended interval between regrinds.
- Hardened double-D key for precise orientation of punches for improved piece part quality.
- 1/4 degree back taper and near polished punch flanks to reduce friction, eliminate galling, and maximize punch life.
- Maxima® coating available for extreme applications to reduce galling and improve stripping.

STRIPPER GUIDE

- Hardened and ground with superior concentricity for reduced friction and longer tool life.
- Smooth rounded edges to eliminate sheet marking and improve piece part quality.
- Compatible with existing conventional thin turret tooling inventory for maximum flexibility.

SLUG FREE® DIE

- Slug Free die geometry eliminates slug pulling to improve piece part quality and increase tool life.
- Highly wear-resistant tool steel provides optimum balance between hardness and toughness, for extended service life.



- **Quality**
- **Durability**
- **Reliability**
- **Performance**
- **Compatibility**

[Dimensions in Inches (mm)]



Upper Assembly

Round
Shape

(Includes canister, punch and stripper)

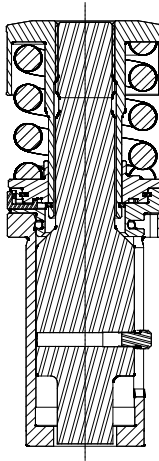

Punch

Round **PRSB0A**
Shape **PBSB_A**

DuraSteel™

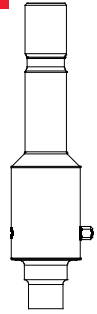

Stripper

Round **SRSB0A**
Shape **SBSB_A**

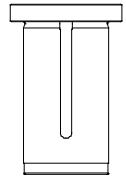

Hardware

1-1/4" Canister
MATE00690

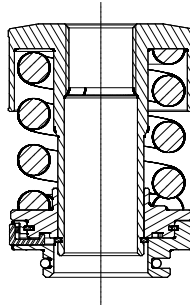

Slug Free® Die

Round **DASB00**
Shape **DASB_0**
Shim Pack **MSAB**

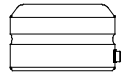

Urethane Slug Ejector—3.00mm	URE40002 (12 minimum)
Urethane Slug Ejector—6.00mm	URE40010 (12 minimum)
Medium India Oil Stone	STO29807

STANDARD SHAPES (NUMBERING INDICATES SHAPE CODE):



[Dimensions in Inches (mm)]

The Mate Xcel™ 2" Guide Assembly and Strippit Style Tooling for 2" thin turret stations is Mate's high performance tooling designed to improve piece part quality and maximize productivity. Punches, dies, and strippers are fully compatible with existing 2" thin turret Strippit Style holders.

MATE XCEL™ 2" GUIDE ASSEMBLY

- Quick length adjustment; push button on guide flange allows punch length adjustment in 0.005(0.13) increments without disassembly or additional tools
- Quick change stripper mechanism; lock button allows tool-less stripper removal and installation
- Hardened guide body reduces friction within the turret and guide key and keyways assure precise punch alignment for higher piece part quality
- Internal and external grooves for enhanced lubrication

PUNCH

- DuraSteel™ with superior hardness and toughness for extended interval between regrinds
- Hardened pin for precise orientation of punches for improved piece part quality
- 1/4 degree back taper and near polished punch flanks to reduce friction, eliminate galling, and maximize punch life
- Maxima™ coating available for extreme applications

STRIPPER

- Smooth rounded edges to eliminate sheet marking and improve piece part quality
- Compatible with existing conventional thin turret tooling inventory for maximum flexibility*

SLUG FREE® DIE

- SLUG FREE die geometry eliminates slug pulling to improve piece part quality and increase tool life
- Highly wear-resistant tool steel provides optimum balance between hardness and toughness, for extended service life



[Dimensions in Inches (mm)]

Holder

Mate Xcel™ 2" Guide Assembly

MATE01715

Punch

Round **PLSC0A**

Shape **PLSC_A**

Stripper

Round **SLSC0A**

Shape **SLSC_A**

SLUG FREE® Die

Round **DCSC00**

Shape **DCSC_0**

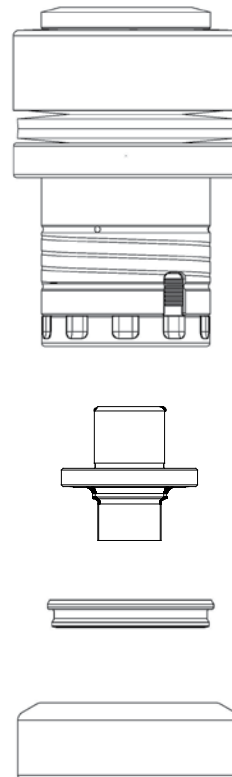

ADD-ONS FOR ROUNDS AND SHAPES:

Urethane Slug Ejector—3.00mm	URE40002 (12 minimum)
Urethane Slug Ejector—6.00mm	URE40010 (12 minimum)
Maxima™ Coating	

Narrow Width

Round point diameter is less than 0.061(1.55) - add
 Round point diameter is less than 0.092(2.35) - add
 Shape point width is less than 0.079(2.00) - add

to punch, stripper and die
 to punch, stripper and die
 to punch, stripper and die

Non-Standard Angle Setting

Punches - add to price
 Dies - add to price

STANDARD SHAPES (NUMBERING INDICATES SHAPE CODE):



[Dimensions in Inches (mm)]

The Mate Xcel™ Tooling System for 3-1/2" stations deliver higher quality piece parts, with greater interval between regrinds. The two Xcel™ Punch Guide Assemblies combine innovative product design, superior material selection and high quality manufacturing processes to deliver unmatched punching performance.

Xcel Guide Assembly for Inch Shank Punches—fully compatible with existing inventory.

Xcel Guide Assembly for Slitting Punch Insert—accepts Mate Premium M4PM™ High Speed Steel inserts.

Both Mate Xcel punch guide assemblies can use conventional strippers (see page 7) for full compatibility with existing inventory, or new fully guided strippers (see page 11) to guide the tip of the punch for superior punching performance.

- **Quick Length Adjustment** —The push button on the flange of the guide allows the punch length to be adjusted in increments of 0.005(0.13) without disassembly or additional tools.
- **Stripper**—Toughened tool steel to maximize service life. Smooth rounded edges to eliminate sheet marking and improve piece part quality.
- **Fully Guided Stripper**—The punch guide assembly holds the stripper rigidly, while the stripper guides the tip of the punch, for truly exceptional fully guided punching performance. Punch to stripper clearance = 0.0017(0.04). Stripper to guide clearance = 0.0006(0.02).
- **Quick Change Stripper Mechanism**—The stripper lock button on the side of the guide releases the simple, replaceable stripper locking ring which allows the standard or fully guided stripper to be installed and removed without additional tools.
- **Hardened Guide Body**—Resists dents and scratches to reduce friction within the turret and extend machine and tool life.
- **Hardened Guide Key**— One-piece key and hardened keyways assure precise alignment of the punch within the guide and the guide within the turret for higher piece part quality and longer tool life.
- **Tool Lubrication**—The guide body includes internal and external grooves to allow efficient delivery of tool lubrication to all critical surfaces.
- **Quick Change Angle Settings**—The upper push button provides quick release of the guide body to allow multiple angle settings to be achieved without additional tooling.



Mate Xcel™ fully guided punch guide assembly, with inch shank punch.



Mate Xcel™ fully guided punch guide assembly, with slitting punch insert.

[Dimensions in Inches (mm)]

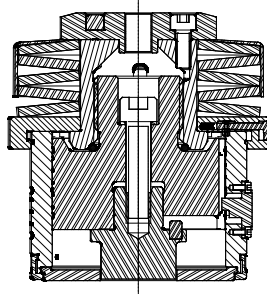

Upper Punch Assembly

DIAGONAL	SHAPE
1.251 to 1.500	Round Shape
1.501 to 2.500	Round Shape
2.501 to 3.500	Round Shape

(Includes punch, stripper and hardware)

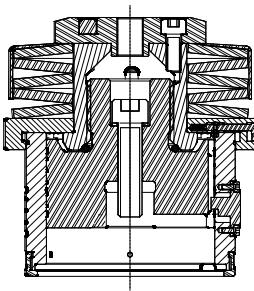

Hardware

3-1/2" Guide **MATE00869**

Inch Shank Punch

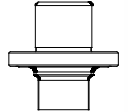

DIAGONAL	SHAPE	PART NUMBER
1.251 to 1.500	Round	PLSD0A
	Shape	PLSD_A
1.501 to 2.500	Round	PLSF0A
	Shape	PLSF_A
2.501 to 3.500	Round	PLSH0A
	Shape	PLSH_A

Maxima® Coating

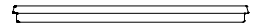

Stripper

Round	SLSD0A
Shape	SLSD_A



Slug Free® Die

Round	DCSD00
Shape	DCSD_0
Shim Pack	MSAD

Urethane Slug Ejector—3.00mm	URE40002 (12 minimum)
Urethane Slug Ejector—6.00mm	URE40010 (12 minimum)
2.5mm Hex Wrench	MIS98896
Medium India Oil Stone	STO29807

Note: This product is manufactured under license from Wilson Tool (Pat. 5,127,293)

STANDARD SHAPES (NUMBERING INDICATES SHAPE CODE):



[Dimensions in Inches (mm)]

Xcel™ Guide Assembly for Inch Shank Punches

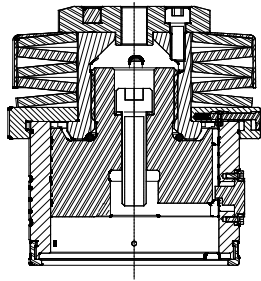

- External length adjustment
- Six angle settings
- Quick change stripper

MATE00869

Xcel™ Guide Assembly for Slitting Punch Inserts

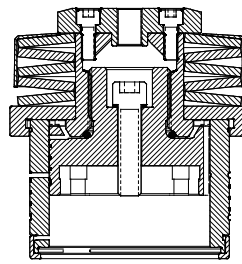

- External length adjustment
- Four angle settings
- Quick change stripper

MATE00868

Inch Shank Punch

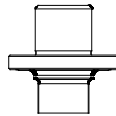

Diagonal	Shape	Part Number
1.251 to 1.500	Round	PLSD0A
	Shape	PLSD_A
1.501 to 2.500	Round	PLSFOA
	Shape	PLSF_A
2.501 to 3.500	Round	PLSH0A
	Shape	PLSH_A

Slitting Punch Insert

Front view



Side view



Shape **PJSQ_A**

Maxima® Coating

Mate M4PM™ High Speed Steel is a very homogeneous, high quality tool steel, with superior wear resistance and increased toughness. Users prove it outperforms conventional tool steels.

The Mate Xcel™ Fully Guided tooling system is the only system to deliver true fully guided punching performance.

- The clearance between the punch and the stripper is 0.0017(0.04).
- The clearance between the stripper and the guide is 0.0006(0.02).

The guide holds the stripper rigidly, while the stripper guides the tip of the punch.

Fully Guided Stripper



Round **SJSD0A**
Shape **SJSD_A**

Slug Free® Die

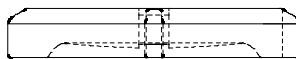

Round **DCSD00**
Shape **DCSD_0**
Shim Pack **MSAD**

Mate Slug Free® dies supplied as standard.

- eliminate slug pulling
- reduce tool breakage
- improve tool life
- increase piece part quality

Mate Xcel™ 3-1/2" Station Punch Guide Accessories

Xcel™ Replacement Locking Ring

MATE00402

Fully compatible with all Xcel punch guide assemblies.

Xcel™ Punch Guide Field Service Kit

MATE00894

Replacement guide body kit for Xcel Slitting Punch Insert Guide Assembly (MATE00868), and Xcel Inch Shank Punch Guide Assembly (MATE00869). Kit includes guide body, guide key and stripper lock button. Also allows Xcel guides (MATE00340) manufactured before July 2007, to be converted to accept fully guided strippers.

Fully compatible with all Xcel punch guide assemblies.

Xcel™ Slitting Insert Punch Driver Kit

MATE00807

Convert existing Xcel Inch Shank Punch Guide Assembly (MATE00869), to accept Slitting Punch Inserts.

Fully compatible with all Xcel punch guide assemblies.

Xcel™ Inch Shank Punch Driver Kit

MATE00896

Convert existing Xcel Slitting Punch Insert Guide Assembly (MATE00868), to accept inch shank punches.

Fully compatible with all Xcel punch guide assemblies.



Note: This product is manufactured under license from Wilson Tool (Pat. 5,127,293)

[Dimensions in Inches (mm)]



Mate Xcel™ Cluster Assemblies are designed to take advantage of the many features offered by the Mate Xcel 3-1/2" Punch Guide Assembly. They combine convenience of replaceable inserts, the precision of the integrated punch driver, and the performance of the Mate Xcel 3-1/2" Punch Guide Assembly.

Mate Xcel Cluster Assemblies combine many components including:

- **Integrated Punch Driver**—Designed with the same precision as the original punch driver, for precise interchangeability.
- **Punch Inserts**—High Speed Steel punch inserts maximize the interval between regrinds. The near polished punch flanks with 1/4 degree back taper reduce friction and extend punch life. Maxima® coating available for extreme punch applications.
- **Retainer Plate**—Produced using advance Electro Discharge Machining (EDM) technology to guarantee the angularity and concentricity that is essential when using a high performance cluster assembly.
- **Stripper Plate**—Toughened tool steel to maximize service life. Smooth rounded edges to eliminate sheet marking and improve piece part quality.
- **Slug Free® Die**—Eliminates slug pulling to improve piece part quality and increase tool life. Highly wear-resistant tool steel provides optimum balance between hardness and toughness, for extended service life.
- **Mate Xcel™ Guide Assembly**—Complete interchangeability between cluster assemblies and conventional Strippit Style tooling applications. Quick length adjustment and quick change stripper mechanism for rapid tool changes.

Mate Xcel guide assembly required for compatibility with Mate cluster assembly. Allows user to use inch shank punches when not using the cluster assembly.



Cluster assembly is designed to take full advantage of the many features offered by the Xcel 3-1/2" Guide assembly.



Use the quick release features on the guide assembly to disassemble the cluster. Unscrew the integral punch driver assembly.



Re-install the original punch driver supplied with the guide to convert the guide for use with conventional Strippit style tooling.

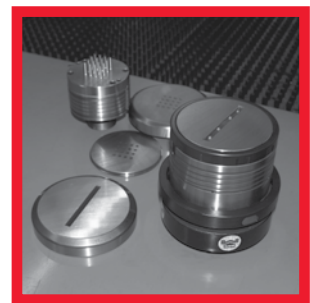

The Mate Xcel 3-1/2" is now ready for use with your conventional Strippit style tooling.

[Dimensions in Inches (mm)]

MATE XCEL™ MAINTENANCE FIXTURE

MATE XCEL™

The Mate Xcel™ maintenance fixture is a multi-function fixture designed to make installation and maintenance of thin turret tooling quick, simple, and reliable. The fixture includes a universal clamp and three Quick-Set locations.

- The universal clamp allows 1/2" Snap-Apart, 5/8" Drop-In, and 1-1/4" Full Body punches to be held securely to allow the installation and adjustment of punch heads, springs, and spring retainers.
- Quick-Set positions 1 and 2 enable tooling with an orientation key to be installed and adjusted without using the universal clamp for added speed. (see drawing below)
- Quick-Set position 3 holds the Mate Xcel™ 3-1/2" guide securely in place to allow the punch draw bolt to be tightened to the correct torque setting for reliable operation. (see drawing below)

The Mate Xcel maintenance fixture can be mounted to a bench, or clamped in a vice, for maximum convenience.



MATE00700

Installation and Use Instructions.

The Mate Xcel™ Maintenance Fixture is simple to install.

- **Bench Mounted**—Use the 3/8-16 x 4" (100mm) bolts supplied to attach the clamp bar, through the bench, to the body of the fixture. Ideal for more permanent installations.
- **Vice Mounted**—Use the 3/8-16 x 2" (50mm) bolts supplied to attach the clamp bar to the body. Then mount the fixture into a vice. Ideal for temporary installations.

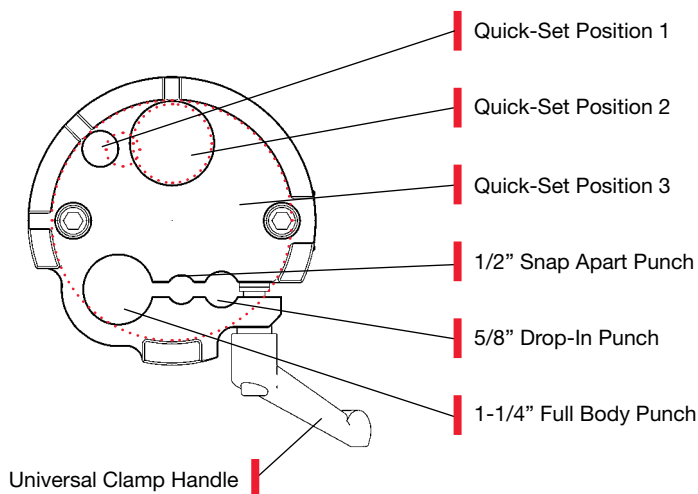

Tooling Description	Feature
1/2" Snap-Apart Punch	Clamp
1/2" Snap-Apart Shaped Punch	Quick-Set 1
5/8" Drop-In Punch	Clamp
5/8" Drop-In Shaped Punch	Quick-Set 1
1-1/4" Full Body Punch	Clamp
1/2" Snap-Apart Assembly	Quick-Set 2
5/8" Drop-In Assembly	Quick-Set 2
1-1/4" Full Body Assembly	Quick-Set 2
3-1/2" Xcel Guide Assembly	Quick-Set 3

[Dimensions in Inches (mm)]



MTG™ LONG — FOR STRIPPIT AND NISSHINBO STYLES

What is a Multi Tool? - It's a tool which expands the capacity of any one station of a CNC press by allowing more than one punch and die set to be placed in a particular machine station. It is different from a cluster tool in that only one punch actuates during a ram cycle.



PUNCH

- Mate DuraSteel™ tool steel with superior hardness and toughness for extended interval between regrinds.
- Hardened double-D key for precise orientation of punches for improved piece part quality.
- 1/4 degree back taper and near polished punch flanks to reduce friction, eliminate galling, and maximize punch life.
- Maxima™ coating available for extreme applications.

STRIPPER

- Hardened and ground with superior concentricity for reduced friction and longer tool life.
- Smooth rounded edges to eliminate sheet marking, improve piece part quality and make installation simple.
- Compatible with existing tooling inventory for maximum flexibility.

SLUG FREE® DIE

- Slug Free die geometry eliminates slug pulling to improve piece part quality and increase tool life.
- Highly wear-resistant tool steel provides optimum balance between hardness and toughness, for extended life.

REFERENCE DIMENSIONS CHART:

Punch:	Strippit	Nisshinbo
Maximum Diagonal	0.500(12.70)	0.630(16.00)
Overall Length (New)	3.942(100.13)	
Shank Diameter	0.630(16.00)	
Head Diameter	0.810(20.57)	
Stripper:		
Outside Diameter	1.057(26.84)	
Thickness	0.286(7.26)	
Stripper Land	0.186(4.72)	
Slug Free® Die:		
Outside Diameter	1.000(25.40)	
Overall Height (new)	0.691(17.55)	

Punch

Round **PNSROA**
Shape **PNSR_A**

Stripper

Round **SNSROA**
Shape **SNSR_A**

Slug Free® Die

Round **DGSR0A**
Shape **DGSR_A**

General Add-Ons:

Radius Corner
Special Angle Settings

Small Diameter Round Tools
Diameter 0.031(0.79) to 0.061(1.55)
Diameter 0.062(1.56) to 0.092(2.34)

Narrow Width Shaped Tools
Widths under 0.078(2.00)

Maxima
MTG™ Long

MTG™ — 3 STATION AND 8 STATION

MTG™ 3 Station (1.250)

Punch - Durasteel™
Round **PMSQ0A**
Shape **PMSQ_A**
Maxima® Coating

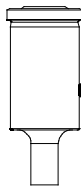

Stripper
Round **SMSQ0A**
Shape **SMSQ_A**



Die
Round **DESQ00**
Shape **DESQ_0**



MTG™ 8 Station (0.500)

Punch - Durasteel™
Round **PMSROA**
Shape **PMSR_A**
Maxima® Coating



Stripper
Round **SMSROA**
Shape **SMSR_A**



Die
Round **DESR00**
Shape **DESR_0**



[Dimensions in Inches (mm)]

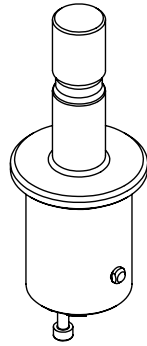

1-1/4" Station Upper Insert Holder Assembly
MATE00405

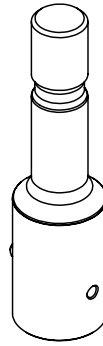

1-1/4" Station Upper Insert Holder Assembly—
MATE00417

STRIPPIT STYLE FOR FORMING UNITS FOR 3-1/2" STATION

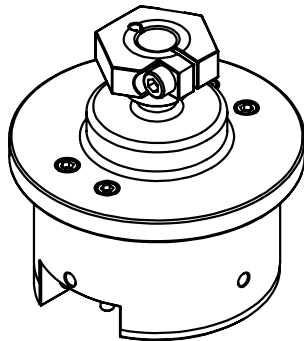

3-1/2" Station Guide Body Assembly—
MATE00412

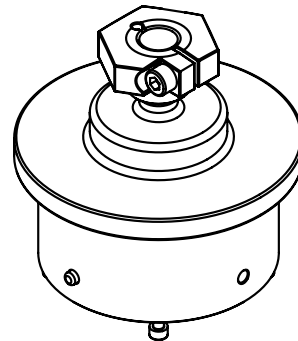

3-1/2" Station Guide Body Assembly—
MATE00414

[Dimensions in Inches (mm)]



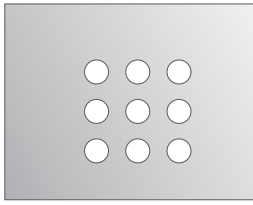

Cluster - Round

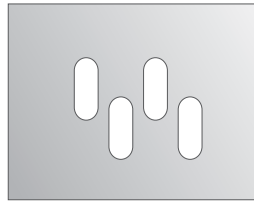

Cluster - Shape

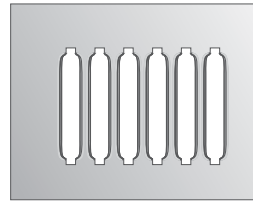

Card Guide



Centerpoint



Countersink - Round



Countersink - Shape



Emboss - Beading



Emboss - Edgeform

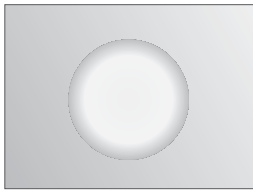

**Emboss - Formed
(Round and Shaped)**



Emboss - Cold Forged



Extrusion - Tapping



**Extrusion -
Flanged Hole**

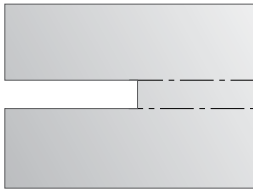

Guided Shearing



Hinge Tool

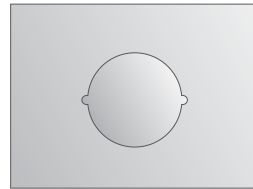

Knockout



Lance and Form



Louver

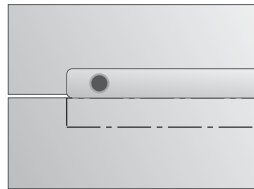

Scissors tool™

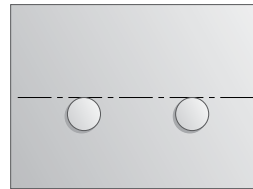

Shearbutton



Rollerball™



Sheetmarker™



Stamping - Alpha Numeric

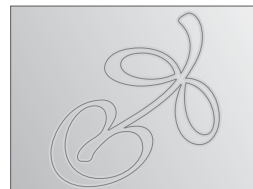

Stamping - V-line

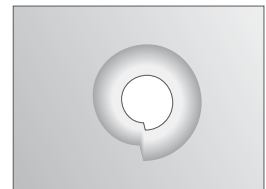

Threadform

[Dimensions in Inches (mm)]

Cluster**Use:**

To produce multiple holes with minimal hits.

Typical Application:

Material thickness from 0.020(0.50) to 0.157(4.00).

Other constraints dependent upon station size, punch size and shape and press tonnage capacity.

Comments:

For greater hole uniformity and flatter sheets, spread the punches to avoid punching adjacent holes in the same hit.

Complete the desired pattern with the technique known as bridge hitting.

Do not re-punch through previously punched holes to complete a pattern, single hit tool may be necessary.

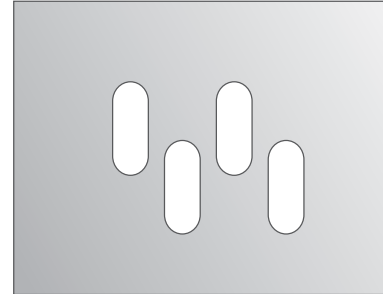
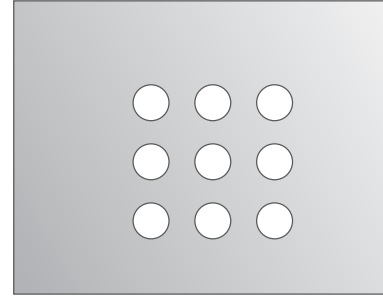
**Card Guide****Use:**

As a retainer for printed circuit boards.

Typical Application:

Material thickness from 0.040(1.00) to 0.078(2.00).

Maximum recommended top-to-top height 0.125(3.20).

Comments:

Length of the card guide is dependent upon station size and machine tonnage.

Also available as a continuous type form to increase productivity.

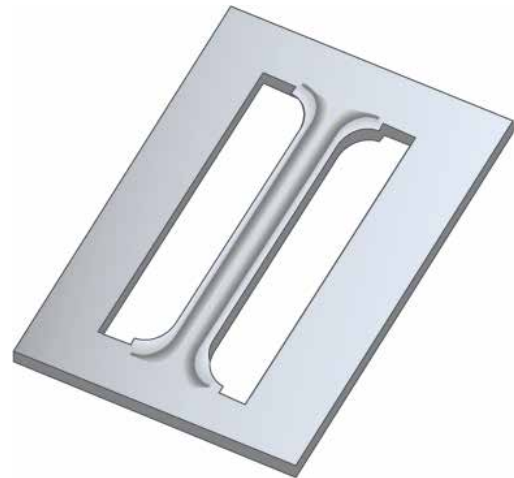

[Dimensions in Inches (mm)]

Countersink

Use:

Allows screw head to reside flush or below the surface of the material.

Typical Application:

Material thickness from 0.048(1.22) to 0.250(6.35), dependent upon press tonnage capacity.

Comments:

The shoulder style (dedicated) is generally ordered for one material thickness and screw size.

The shoulder style coins the surrounding area producing a clean flat countersink with minimal burring.



Emboss - Beading

Use:

As a stiffener to add rigidity to sheet metal panels.

Typical Application:

Material thickness from 0.027(0.70) to 0.250(6.35), dependent upon press tonnage capacity.

Comments:

Increments between hits are determined by the cosmetic requirements for the finished part. Smaller increments result in better appearance.

To minimize the sheet distortion that results from forming metal, the form height should be as low as possible.



Emboss - Cold Forged**Use:**

To produce a logo or design on a part.

Typical Application:

Material thickness from 0.018(0.46) to 0.118(3.00).

Best results in material thickness from 0.040(1.00) to 0.078(2.00).

Maximum size dependent on the tooling style, station size and press tonnage capacity.

Comments:

An exact drawing, CAD file or sample of logo is required in order to produce this type of assembly.

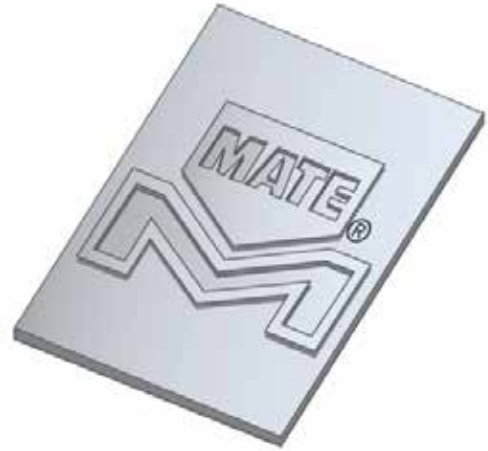
**Emboss - Formed****Use:**

Provides a recess or a protrusion.

Typical Application:

Material thickness from 0.027(0.70) to 0.250(6.35), dependent upon press tonnage capacity.

Comments:

Best results are attained when the side wall angle is 45° or less.

Optimum form height is 3 times the material thickness or less.



[Dimensions in Inches (mm)]

Extrusion - Tapping

Use:

Threading for screws and increased bearing area for tubes, etc.

Typical Application:

Material thickness from 0.031(0.80) to 0.106(2.70).

Overall Height—2x to 2.5x material thickness.

Diameter—0.374(9.50) (M-10).

Comments:

Buy additional inverted dies to accommodate alternate material thicknesses.

Maximum diameter can be increased by using an alternative design.



Hinge

Use:

To create hinge knuckles as integral elements on sheet metal components.

Typical Application:

The range of this application is dependent on a combination of the material thickness, pin diameter, and feed gap of the press.

Comments:

An integral hinge knuckle on a component eliminates the costly process of purchasing and assembling separate hinges.

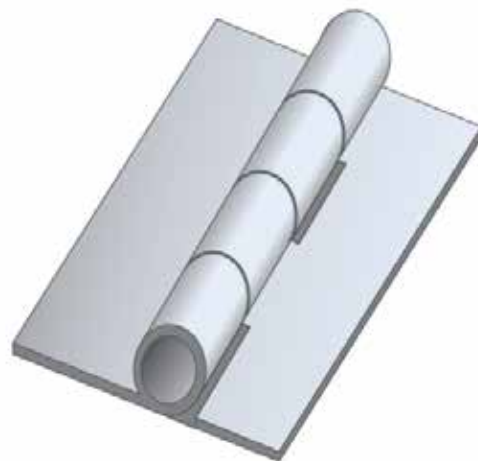

[Dimensions in Inches (mm)]

Knockout

Use:

Allows optional pathway for electrical cable.

Typical Application:

Material thickness from 0.024(0.60) to 0.118(3.00).

Maximum size dependent upon material type, thickness, and press tonnage capacity.

Comments:

The tool can be used with other material thickness within a range of + or - 0.016(0.40) from design thickness.

Maintain minimum of 0.236(6.00) difference between diameters used for knockout.



Louver

Use:

To provide air flow or ventilation.

Typical Application:

Material thickness from 0.028(0.70) to 0.106(2.70).

Maximum recommended top-to-top height is 0.255(6.50).

Comments:

One tool cuts the sheet and produces the form in the same operation. The tool is designed for a specific material thickness.



[Dimensions in Inches (mm)]

Lance and Form

Use:

For air flow, decoration, card guides, location markers, shear tabs, wire harnesses or clip attachments.

Typical Application:

Material thickness from 0.020(0.50) thick to 0.118(3.00).
Maximum recommended top-to-top height is 0.250(6.40).
Other limitations include material type, thickness, station size and press tonnage capacity.

Comments:

The inclusion of a 5° draft angle is recommended to assure reliable operation.



Stamping—Alpha Numeric

Use:

To provide indelible marking of alpha-numeric characters on the top or bottom of the sheet. Example: part numbers.

Typical Application:

Material thickness from 0.032(0.80) up to machine capacity.
Characters available in 4 popular sizes. See table.

Comments:

Each individual character can be changed easily.

INSERT SIZES AVAILABLE

Fractional Inch	Decimal Inch	Metric
3/32	0.094	2.40
1/8	0.125	3.12
3/16	0.188	4.50
1/4	0.250	6.35

[Dimensions in Inches (mm)]

Stamping—V-Line Inscription

Use:

To produce logos, messages or symbols.

Typical Application:

Material thickness from 0.032(0.80) up to machine capacity.
Maximum size is dependent on station size and size of symbols and characters and press tonnage capacity.

Comments:

V-Line Stamping—renders the image with a thin, sharp line stamped into the surface.

An exact drawing, CAD file, or sample of logo is required in order to produce this type of assembly.



Threadform

Use:

To provide a form to accept a sheet metal screw (button head).

Typical Application:

Material thickness from 0.020(0.50) to 0.048(1.20).
Size is dependent upon screw size selected.
Thicker material requires a countersink operation or thinning prior to threadforming.

Comments:

Tool can be designed to suit either cut thread or rolled thread.
You will need to specify thread type when ordering.

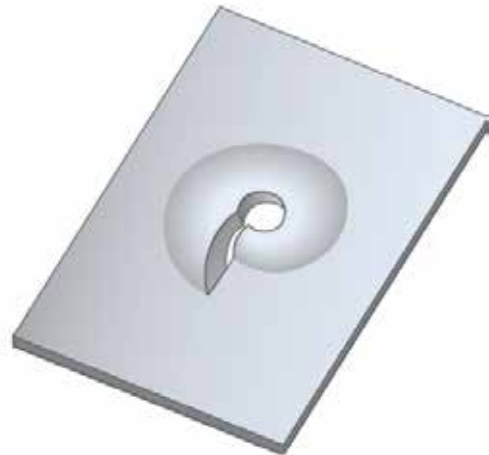

[Dimensions in Inches (mm)]

Mate Rollerball®**Use:**

The Rollerball® is an exciting new tool designed by Mate Precision Technologies to take advantage of the extended programming capabilities of hydraulic and other punch presses capable of operating in the X and Y axis with the ram down. The Rollerball® gives you the benefit of making forms not possible with single hit forming tools.

Typical Application:

Maximum workable material thickness is 0.105(2.70) mild steel.

Comments:

The press must be capable of holding the ram down while the sheet is moved on the X or Y axis.

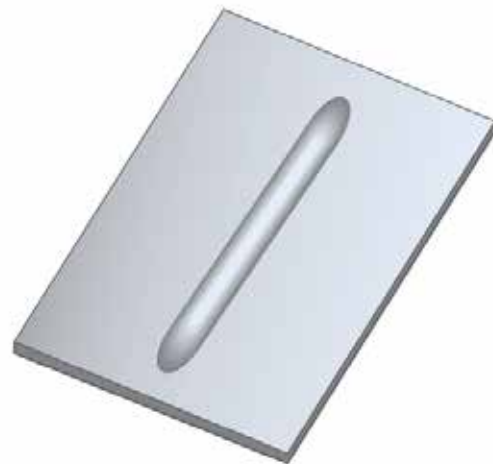
**Mate Sheetmarker®****Use:**

For markings or etchings on the surface of sheet metal. The tool uses a diamond pointed insert in a spring loaded holder to create the marking.

Typical Application:

The Sheetmarker® Tool can be used on all material types and thickness.

Comments:

A wide variety of results can be produced, ranging from very light etching to fairly deep grooves in the sheet.

Variations are achieved with a combination of three spring pressures and insert point angles.



Mate SnapLock™

Use:

For joining materials, thus eliminating secondary operations such as spot welding, riveting, or fastening with threaded hardware.

Typical Application:

Material thickness from 0.020(0.50) up to 0.118(3.00).
Other limitations include material type, station size, and press tonnage capacity.

Comments:

Suitable for joining materials of dissimilar type and/or thickness.
Positive locking and locating feature for fast and accurate assembly.

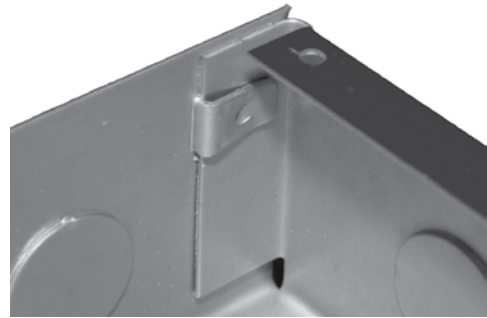
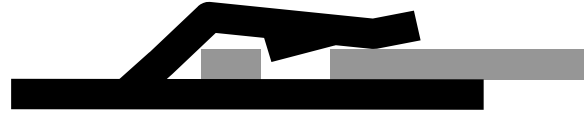

Mate HexLock™

Use:

To provide a reliable and secure method of retaining common threaded fasteners in sheet metal.

Typical Application:

Material thickness from 0.020(0.50) up to 0.118(3.00).
Other limitations include material type, station size, and press tonnage capacity.

Comments:

Suitable for hexagon nuts and hexagon headed bolts that conform to DIN933 or DIN934

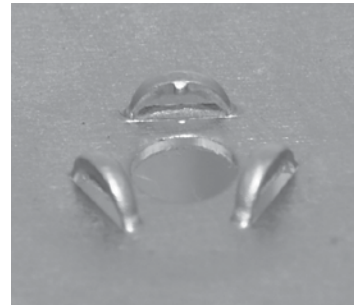

[Dimensions in Inches (mm)]

Mate EasySnap™

Use:

Scrapless retention system to allow fabricator to snap punched parts out of sheet metal.

Typical Application:

Material thickness from 0.020(0.50) up to 0.078(2.00) for mild steel and aluminium, and 0.020(0.50) up to 0.059(1.50) for stainless steel.

Comments:

Reduces the need for slitting and micro joints for part retention. Material type and thickness must be specified at time of order.

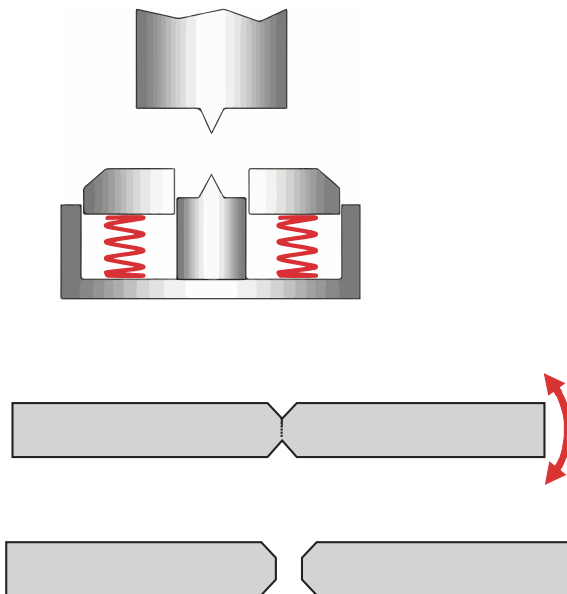

Mate 19" Racking Cluster

Use:

For high speed punching of the mounting hole pattern commonly found in electronic and telecommunications cabinets. The hole spacing conforms to DIN41494, IEC 297 and BS 5954.

Typical Application:

Material thickness from 0.020(0.50) up to 0.157(4.00)

Comments:

Special shape "U" pitch marker on the central punch point allows the end user to count pitches, not holes!

Solid (non-insert) style cluster tools and insert style cluster assembly options available.

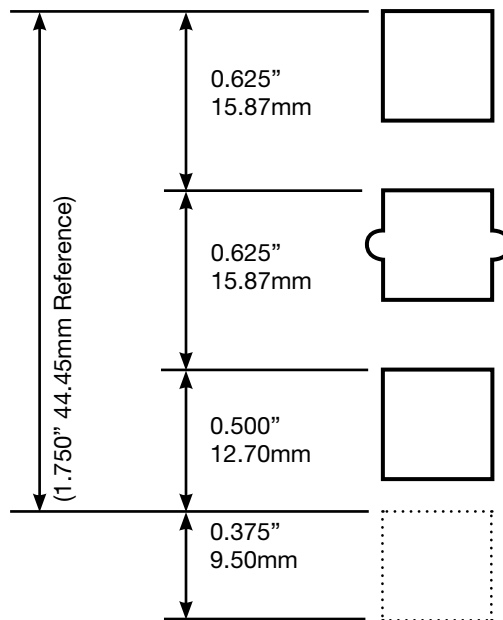

[Dimensions in Inches (mm)]

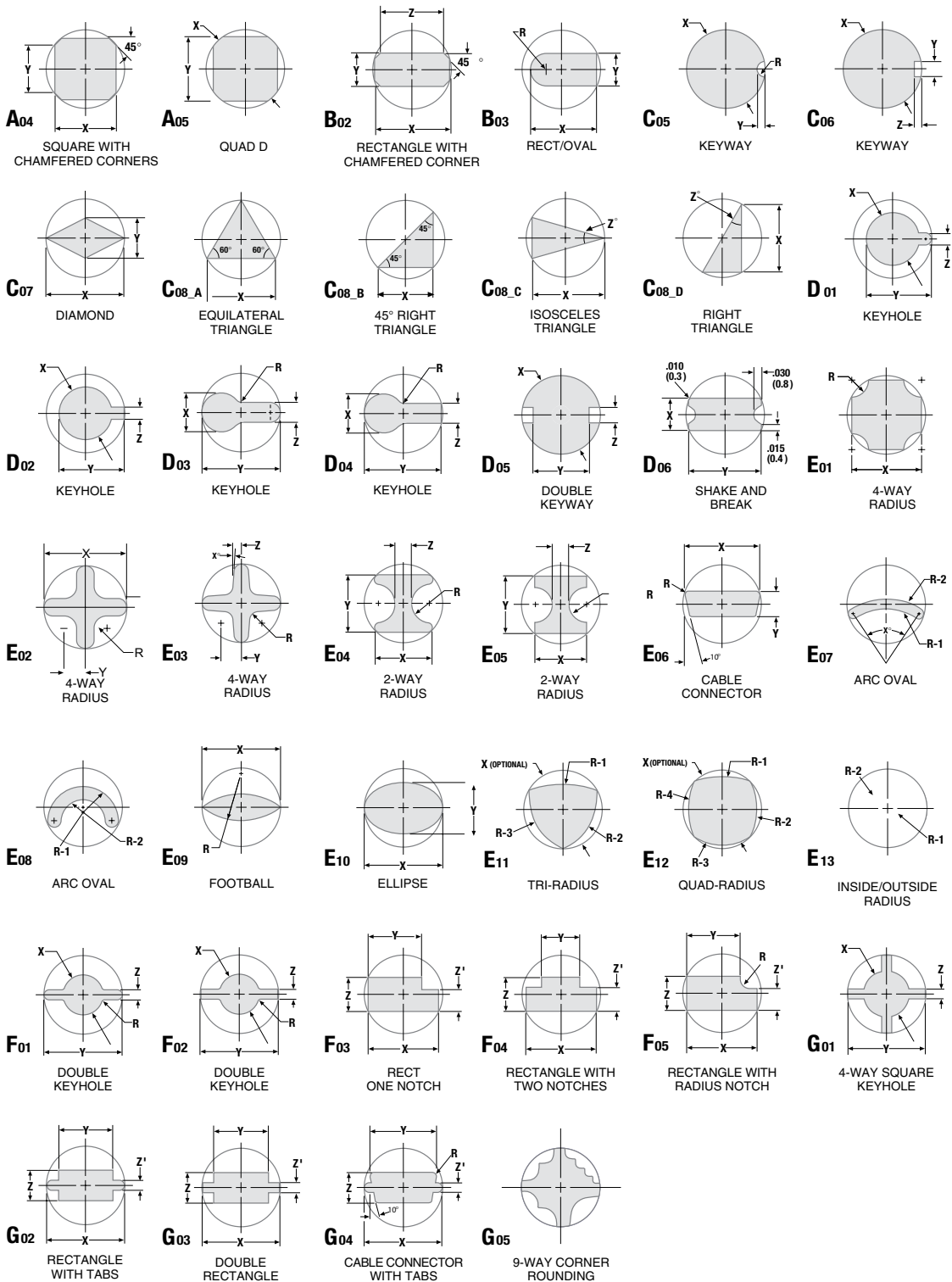

[Dimensions in Inches (mm)]



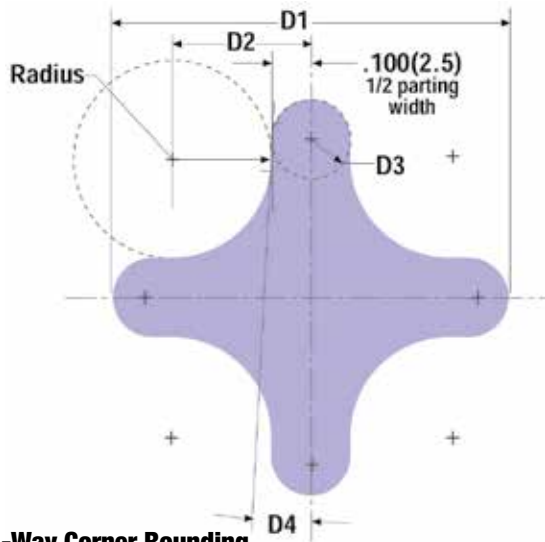

4-Way Corner Rounding

The 4-way corner rounding tool can round all four corners of a piece part without rotating the tooling—use with standard parting tools for piece part separation.

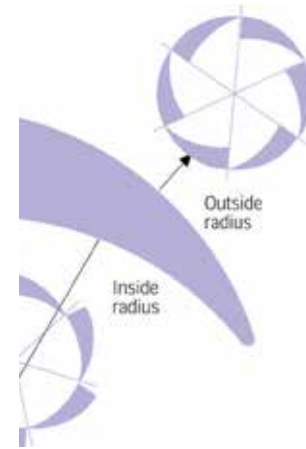

Inside/Outside Radius

This tool's large radii results in blanks with smoother edges produced in fewer hits than with an ordinary radius punch. This tool can be programmed to punch holes with slugs or parts retained in the sheet, yet can be separated easily off the press.

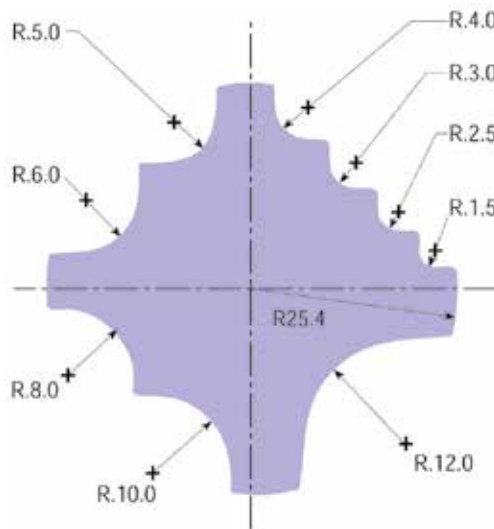

9-Way Corner Rounding

A single 9-way corner rounding tool provides nine popular radii in one tool. Auto-indexing selects and rotates the desired radius to round off all corners of a piece part. Alternate radii can be specified in inch or metric sizes.

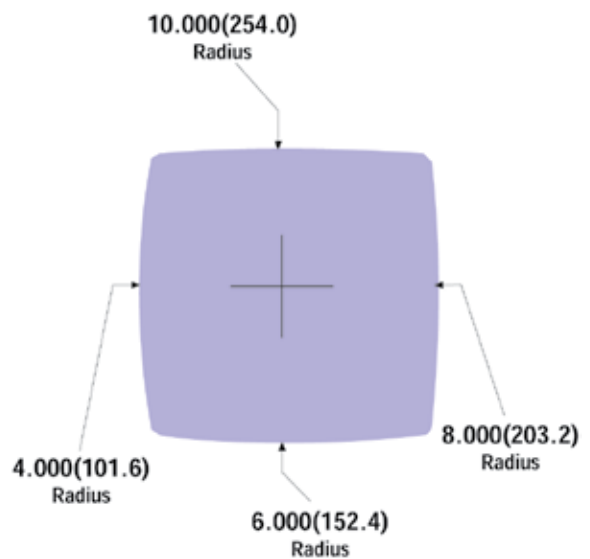

Quad Radius

The quad radius tool nibbles large holes with smoother edges and fewer hits than using a round nibbling punch. Smooth round holes are not limited to station range. Alternate radii can be specified in inch or metric sizes.

[Dimensions in Inches (mm)]

TOTAL DIE CLEARANCE AND HOLE QUALITY

Die clearance is equal to the space between the punch and die when the punch enters the die opening. It is always expressed as the TOTAL Clearance or TC. Using the correct die clearance increases tool life and improves piece part quality. The chart is based on experiences from our customers who achieve superior piece part quality and the longest possible tool life. Use the chart to determine the optimum clearance (percentage of material thickness) for piercing and blanking operations.

Blanking Tools are used to punch out a small part down the slug chute.

Material Type (Typical Shear Strength)	Material Thickness (T)	PIERCING	BLANKING
		Total Die Clearance (% of T)	Total Die Clearance (% of T)
Aluminum 25,000 psi (0.172 kN/mm ²)	Less than 0.098(2.50)	15%	15%
	0.098(2.50) through 0.197(5.00)	20%	15%
	Greater than 0.197(5.00)	25%	20%
Mild Steel 50,000 psi (0.344 kN/mm ²)	Less than 0.118(3.00)	20%	15%
	0.118(3.00) through 0.237(6.00)	25%	20%
	Greater than 0.237(6.00)	30%	20%
Stainless Steel 75,000 psi (0.517 kN/mm ²)	Less than 0.059(1.50)	20%	15%
	0.059(1.50) through 0.110(2.80)	25%	20%
	0.110(2.80) through 0.157(4.00)	30%	20%
	Greater than 0.157(4.00)	35%	25%

WHAT IS DIE CLEARANCE?

Die clearance is equal to the space between punch and die when the punch enters the die opening.

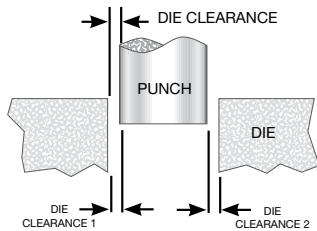

Total Die Clearance = Die Clearance on both sides of punch
 Total Die Clearance = Die Clearance 1 + Die Clearance 2
 Regardless of sheet thickness, the recommended penetration of the punch into a Slug Free® die is 0.118(3.00).

ANATOMY OF A PUNCHED HOLE

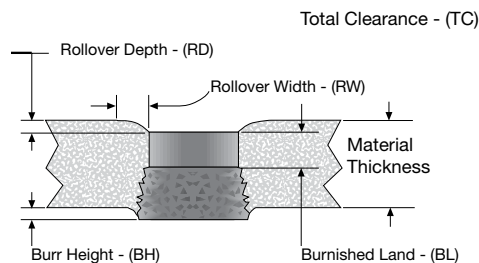

WHY USE PROPER DIE CLEARANCE?

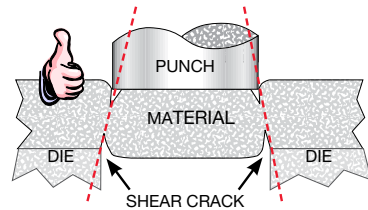

PROPER CLEARANCE - shear cracks join, balancing punching force, piece part quality, and tool life.

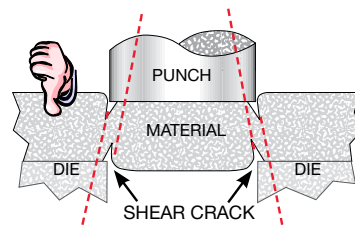

CLEARANCE TOO SMALL - secondary shear cracks are created, raising punching force, and shortening tool life.

[Dimensions in Inches (mm)]

CALCULATING PUNCHING FORCE

Tonnage Formula: Tonnage = Punch Perimeter x Material Thickness x Material Tonnage Value x Material Multiplier

EXAMPLE OF TONNAGE CALCULATION

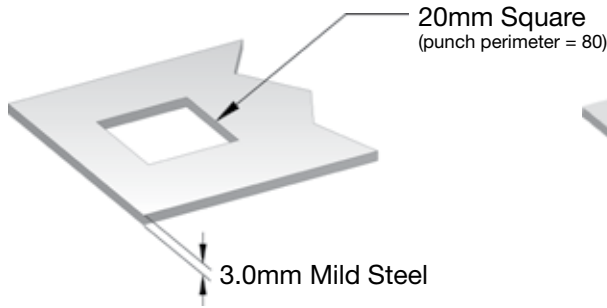

Metric Example:

Metric Tonnage for a 20mm square in 3.0mm Mild Steel
 Tonnage = 80 x 3.0 x 0.0352 x 1.0 = 8.45 Metric Tons

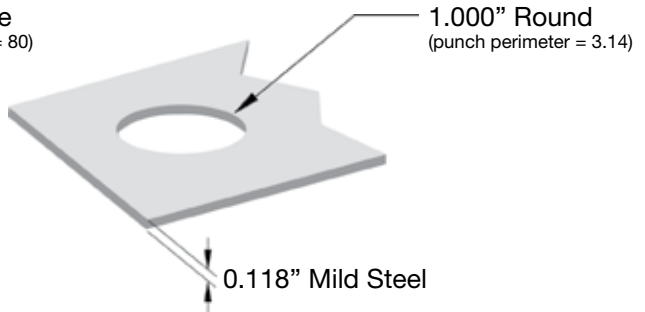

Inch Example:

Imperial Tonnage for a 1.000 inch round in 0.118 inch Mild Steel
 Tonnage = 3.14 x 0.118 x 25 x 1.0 = 9.27 Imperial Tons

MATERIAL THICKNESS

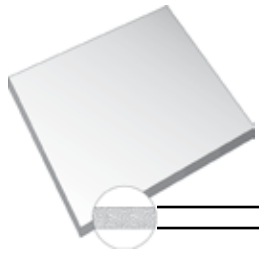

Material thickness is the width of the workpiece or sheet that the punch must penetrate in making a hole. Generally the thicker the material the more difficult it is to punch.

Material Thickness

MATERIAL TONNAGE VALUE

INCH (IMPERIAL TONS/IN²)
25

METRIC (METRIC TONNES/MM²)
0.0352

MATERIAL MULTIPLIER

MATERIAL TYPE	MATERIAL MULTIPLIER
Aluminum (soft sheet)	0.30
Aluminum (1/2 hard)	0.40
Aluminum (full hard)	0.50
Copper (rolled)	0.60
Brass (soft sheet)	0.60
Brass (1/2 hard)	0.70
Mild Steel	1.00
Stainless Steel	1.60

PUNCHING FORCE CHANGES AS TOOLS DULL

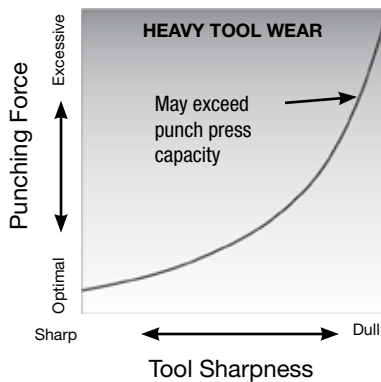

[Dimensions in Inches (mm)]

ANGLE SETTING DETAILS

DIE VIEW

SPECIFY THE DESIRED ANGLE, COUNTERCLOCKWISE FROM 0°, WHEN ORDERING CUSTOM DESIGNS

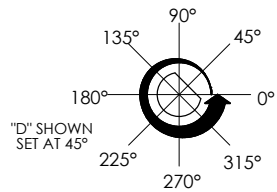
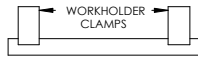
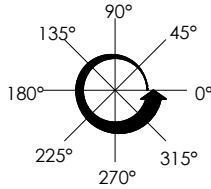

LEGEND

- = PUNCH
- = STRIPPER
- = DIE

SYMBOL OMITTED WHEN ORIENTATION IS NOT REQUIRED

PRIMARY KEY, PIN, OR SLOT ORIENTATION	
MTG 3 STATION (1.250")	MTG 8 STATION (0.500")
+	+

PRIMARY KEY, PIN, FLAT, HOLE, LUG OR SLOT ORIENTATION					
1/2" SNAP APART	5/8" DROP IN	1-1/4" FULL BODY *1-1/4" FULL BODY KEYED STYLE (ROUNDS ONLY)	2" STRIPPIT	3-1/2" STRIPPIT	3-1/2" INCH SHANK
+	+	+	+	+	+

ROUND	RECTANGLE	OVAL	SQUARE	SINGLE D	DOUBLE D	HEXAGON	OCTAGON
+	+	+	+	+	+	+	+

ADD-ONS FOR ROUNDS AND SHAPES

Narrow Width

- Round point diameter is less than 0.061(1.55) - add to punch, stripper and die.
- Round point diameter is less than 0.092(2.35) - add to punch, stripper and die.
- Shape point width is less than 0.079(2.00) - add to punch, stripper and die.

Non-Standard Angle Setting

- Punches - add to price for all stations.
- Stripper - add to price for 1/2", 5/8" and 1-1/4" stations only.
- Dies - add to price for all stations.

Treatments and Coating for Punches

	Nitride	Maxima®	SuperMax®
1/2" Snap Apart	N/A		
5/8" Drop-In	N/A		
1-1/4" Full Body	N/A		
3-1/2" Xcel Inch Shank	N/A		
1-1/4" Xcel™	N/A		
3-1/2" Xcel™ Slitting Punch Insert			
MTG™ 8 Station Multi Tool	N/A		
MTG™ 3 Station Multi Tool	N/A		

[Dimensions in Inches (mm)]



	1/2"	5/8"	1-1/4"	3-1/2"	3-1/2"	MTG™	MTG™
Tool Style	Snap-Apart	Drop-In	Full Body	Inch Shank	Slitting Insert	8 Station	3 Station
Maximum Diagonal	0.500(12.70)	0.625(14.87)	1.250(31.70)	3.500(88.90)	3.500(88.90)	0.500(12.70)	1.250(31.70)

Punch

	PCSA	PDSX	PBSB	PLSD, F, H	PJSQ	PMSR	PMSQ
Part Number Pre-Fix							
Head Diameter	N/A	N/A	N/A	N/A	N/A	0.750(19.10)	1.375(34.93)
Overall Length	5.480(131.19)	5.480(131.19)	5.480(131.19)	1.905(48.39)	2.040(51.82)	2.935(74.55)	3.250(82.55)
Shank Diameter	0.500(12.70)	0.625(14.87)	0.750(19.10)	1.000(25.40)	N/A	0.512(13.00)	1.250(31.70)
Body Diameter	N/A	N/A	1.250(31.70)	Variable	N/A	N/A	N/A
Thread	1/2-20	5/8-18	3/4-16	1/2-13	1/2-13	N/A	N/A
Shank Width	N/A	N/A	N/A	N/A	3.040(77.22)	N/A	N/A
Shank Thickness	N/A	N/A	N/A	N/A	0.7085(17.99)	N/A	N/A

Stripper

	SCSA	SDSX	SBSB	SLSD	SJSD	SMSR	SMSQ
Part Number Pre-Fix							
Thickness/Overall Length	0.600(15.24)	0.600(15.24)	3.032(77.01)	0.281(7.13)	0.281(7.13)	0.286(7.26)	0.250(6.35)
Outside Diameter	1.056(26.82)	1.056(26.82)	1.500(38.10)	3.995(101.47)	4.000(101.60)	1.056(26.82)	1.573(39.95)
Shoulder Diameter	N/A	N/A	1.975(50.17)	3.870(98.29)	3.870(98.29)	N/A	N/A

	SESX
Part Number Pre-Fix	
Thickness	0.286(7.26)
Outside Diameter	1.056(26.82)

Die

	DASB	DASB	DASB	DCSD	DCSD	DESR	DESQ
Part Number Pre-Fix							
Die Diameter	1.875(47.63)	1.875(47.63)	1.875(47.63)	4.937(125.40)	4.937(125.40)	1.000(25.40)	1.875(47.63)
Die Thickness	1.187(30.15)	1.187(30.15)	1.187(30.15)	0.850(21.59)	0.850(21.59)	0.596(15.14)	0.596(15.14)

Punch Grind Life*

	PCSA	PDSX	PBSB	PLSD, F, H	PJSQ	PMSR	PMSQ
Part Number Pre-Fix							
Punch Width	>0.126(3.20)	>0.126(3.20)	>0.126(3.20)	>0.197(5.00)	>0.197(5.00)	>0.094(2.39)	>0.156(3.96)
Punch Length	>0.157(3.99)	>0.157(3.99)	>0.157(3.99)			>0.094(2.39)	>0.187(4.75)
Straight Before Radius	0.722(18.34)	0.722(18.34)	0.722(18.34)	0.657(16.69)	0.906(23.01)	0.655(16.64)	0.750(19.05)
Stripper Land	0.141(3.58)	0.141(3.58)	0.258(6.55)	0.221(5.61)	0.221(5.61)	0.186(4.72)	0.240(6.10)
Material Thickness	0.048(1.22)	0.048(1.22)	0.048(1.22)	0.048(1.22)	0.048(1.22)	0.048(1.22)	0.048(1.22)
Die Penetration**	0.125(3.18)	0.125(3.18)	0.125(3.18)	0.125(3.18)	0.125(3.18)	0.125(3.18)	0.125(3.18)
Punch Grind Life*	0.408(10.36)	0.408(10.36)	0.291(7.39)	0.263(6.68)	0.433(11.00)	0.296(7.52)	0.337(8.56)

* Adjust the material thickness to determine the specific grind life for your application.

** Based on a 5.375(136.53) machine shut height.

*** All dimensions are approximate and are to assist with product identification only. Contact Customer Services for specific information.

NOTES

[Dimensions in Inches (mm)]



[Dimensions in Inches (mm)]





MATE PRECISION TECHNOLOGIES GLOBAL COVERAGE

WORLDWIDE HEADQUARTERS:

1295 Lund Boulevard, Anoka, Minnesota 55303 USA
Tel +1.763.421.0230 mate.com

orders@mate.com