

LASER

PN

AMADA



High Performance Laser Consumables

AMADA®

CO2 & FIBER LASER

- NOZZLES
- OPTICS
- ACCESSORIES



Headquartered in Anoka, Minnesota, in a 300,000 sq. ft. (28,000m²) state-of-the-art facility.

SEVEN DECADES OF EXCELLENCE

Founded in 1962, Mate is a world-class manufacturer of superior solutions for the metal cutting and metal forming industries. We manufacture workholding systems, CNC punch press tooling, and offer a complete line of press brake tooling and laser consumables. Mate products and services are available worldwide, fully supported by more than 80 dealers in every industrialized country.

PERSONAL, RESPECTFUL RELATIONSHIPS

Mate does business with people, not companies. Our connection to you is personal. Mate's team of manufacturing and metalworking professionals knows what you go through. We know what it's like to compete for that next job, manage deadlines or even need a rescue. With Mate you have a partner that respects your knowledge and is dedicated to helping you succeed.

YOUR GO-TO SOURCE

Serving our customers is at the core of who we are. In your plant or on the phone, we're up for whatever metalworking challenges you face. Your Mate representatives are experts who know from experience what happens on the shop floor and provide our legendary in-field support. They speak your language, fully capable of helping you improve processes and solve problems. Mate customer service is ready to assist with fast quotes, guiding your order on to our top-notch machinists and shipping pros.

GET INSPIRED!

With our vast knowledge and broad product range we inspire innovative thinking. Our customer's projects can be seen around the world: from unique building façades thought to be impossible to make, to a new way to add strength to thin material. The possibilities are endless, so think big, bold and beyond.

WE'VE GOT YOU COVERED

Dedicated to quality in every aspect of our business, Mate offers an extensive standard product line that can be delivered with same day or next day service. All Mate products are backed with our industry leading 100% customer satisfaction guarantee.



MATE'S MISSION AND PROMISE TO YOU:

Mate's mission is to personally **Respect, Support** and **Inspire** metalworking professionals around the world with high-quality products and services for factory productivity.

[Dimensions in Inches (mm)]



PERFORMAX™

Performax™ CO2 Laser Lenses (MLL Series)

MATE PERFORMAX™ – the production lens for consistent CO2 laser performance

- Ideal for general laser cutting 4Kw and less
- Rated at less than 0.20% absorption, among the lowest standard lenses on the market
- Superior polishing for a smoother, easier to clean surface. Polished to a 20/10 scratch/dig specification to resist spatter and stay clean longer



PEAK™

Low Absorption CO2 Laser Lenses (MLP Series)

The difference is clear: MATE PEAK™ low absorption, high performance CO2 laser lenses for demanding applications or high power cutting

- Less than 0.15% absorption offers improved cut quality, consistency and longer lens life
- Helium Neon (HeNe) laser beam compatible for better part alignment
- Proprietary clear coating offers superior lens stability, and allows for lens inspection and stress analysis
- Reduces optical distortion and focal length shift



BLACKMAGIC™

Low Absorption CO2 Laser Lenses (MLB Series)

- Increased performance and versatility: Produce improved cuts on aluminum, stainless and other materials
- Coating: Black Magic lenses have the most durable coating in the industry and are spatter resistant
- Impervious to humidity: Work well regardless of humidity for assured efficiency
- Cost savings: Usually last twice as long or more as standard lenses



1 MICRON OPTICS

Fiber Laser Optics (MLF and MLW Series)

- Lower absorption for maximum cut quality and extended optic life
- Clear coating offers superior lens stability
- Consistent performance: Manufactured to exceptionally high tolerances for consistent performance and uniform cutting
- Approved by leading OEMs



FLOWMASTER™

Nozzles and Nozzle Holders (MLN Series)

MATE FLOWMASTER™ nozzles are available in single and double style

- Highest quality copper alloy, stainless and hard stainless material
- Precision manufactured to tight tolerances of +/- 0-10 microns
- Micro-finished internal surfaces improve airflow
- Available for most OEM laser machine manufacturers
- Mate® carries over 2000 types of laser MLN nozzles and nozzle holders
- Manufactured to exacting standards to eliminate unnecessary variables and costly cutting problems for maximum productivity



[Dimensions in Inches (mm)]

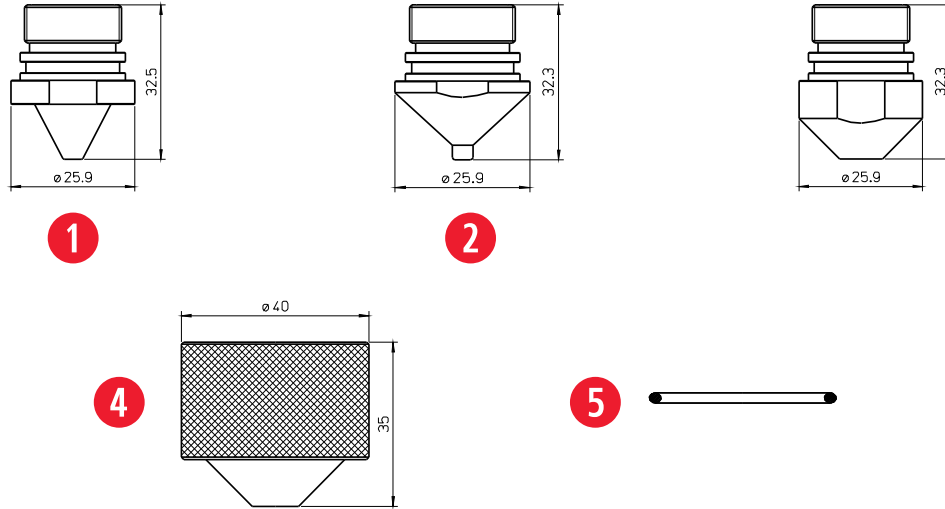

POS	MATE PART NUMBER	OEM CODE	ALTERNATE CODE	PART DESCRIPTION
1	MLN00070	6506892	L81X	SINGLE - 1.3MM NOZZLE CHROME
	MLN00071	6506892	L92X	SINGLE - 1.5MM NOZZLE CHROME
	MLN00072	6506892	L93X	SINGLE - 1.8MM NOZZLE CHROME
2	MLN00002	71101901	L63X	SINGLE - 1.3MM NOZZLE CHROME
	MLN00003	71101902	L91X	SINGLE - 1.5MM NOZZLE CHROME
	MLN00004	71101901	L75X	SINGLE - 1.8MM NOZZLE CHROME
	MLN00005	71101901, 845735	L29X	SINGLE - 2.0MM NOZZLE CHROME
	MLN00600		L809X	SINGLE - 2.5MM NOZZLE CHROME
3	MLN00006		L297X	SINGLE - 1.3MM NOZZLE CHROME
	MLN00008	62094001, 71102001	L299X	SINGLE - 1.8MM NOZZLE CHROME
	MLN00010	62094002, 71102005	L301X	SINGLE - 2.5MM NOZZLE CHROME
4	MLN00011	71101905, 841143B	L30X	OUTER NOZZLE CHROME
5	MLN00012	71341685, 1AS-34, 514	AL96	O-RING FOR OUTER NOZZLE

[Dimensions in Inches (mm)]

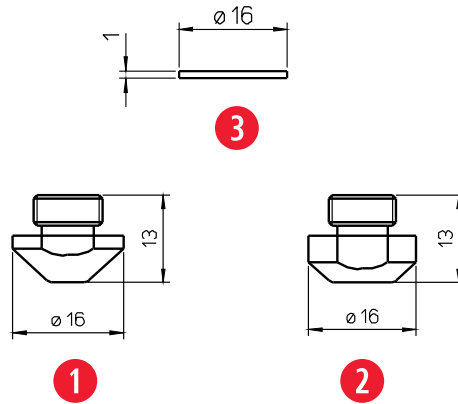

POS	MATE PART NUMBER	OEM CODE	ALTERNATE CODE	PART DESCRIPTION
1	MLN00035	62094006	L171X	SINGLE - 1.0MM NOZZLE CHROME
	MLN00036	62094006	L172X	SINGLE - 1.25MM NOZZLE CHROME
	MLN00037	62094006, 1507610	L173X	SINGLE - 1.5MM NOZZLE CHROME
	MLN00038	62094006	L174X	SINGLE - 1.75MM NOZZLE CHROME
	MLN00039	62094006, 1507611	L27X	SINGLE - 2.0MM NOZZLE CHROME
	MLN00040	62094006	L175X	SINGLE - 2.5MM NOZZLE CHROME
	MLN00041	62094008, 71102007	L28X	SINGLE - 3.0MM NOZZLE CHROME
2	MLN00507	62094005, 71341515	L752X	SINGLE - 1.5MM NOZZLE CHROME
	MLN00523	62094005, 71341515-1,75	L753X	SINGLE - 1.75MM NOZZLE CHROME
	MLN00508	62094005, 71102006	L754X	SINGLE - 2.0MM NOZZLE CHROME
	MLN00509	62094005	L755X	SINGLE - 2.5MM NOZZLE CHROME
	MLN00510	62094005, 71341515-3,0	L756X	SINGLE - 3.0MM NOZZLE CHROME
3	MLN00042	71360259, 62094006	AL107	DISC HEAD PROTECTION Ø 16 PLASTIC

[Dimensions in Inches (mm)]

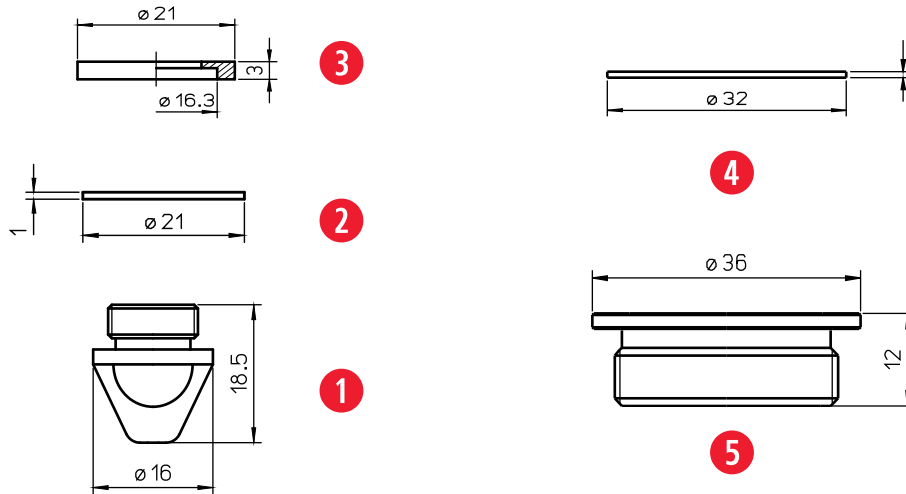

POS	MATE PART NUMBER	OEM CODE	ALTERNATE CODE	PART DESCRIPTION
1	MLN01484		L760X	SINGLE - 0.8MM NOZZLE CHROME
	MLN00044	1664545U	L134X	SINGLE - 1.0MM NOZZLE CHROME
	MLN00045	1664545U	L135X	SINGLE - 1.25MM NOZZLE CHROME
	MLN00046	1664545U, M90115	L86X	SINGLE - 1.5MM NOZZLE CHROME
	MLN00047	1664545U	L136X	SINGLE - 1.75MM NOZZLE CHROME
	MLN00048	1664644U, 71341610, M90114, 62094005	L137X	SINGLE - 2.0MM NOZZLE CHROME
	MLN00049	71341610, 1664545U	L203X	SINGLE - 2.5MM NOZZLE CHROME
	MLN00050	1664645U, 71360142, M90113, 62094008	L138X	SINGLE - 3.0MM NOZZLE CHROME
	MLN00604		L339X	SINGLE - 4.0MM NOZZLE CHROME
	MLN00605		L763X	SINGLE - 5.0MM NOZZLE CHROME
2	MLN00059	71341614, 1669779	AL1005	DISC HEAD PROTECTION Ø 21 PLASTIC
	MLN00060	71341614	AL122	DISC HEAD PROTECTION Ø 21 VESPEL
3	MLN00606		AL123	DISC HEAD PROTECTION Ø 22 CERAMIC
4	MLN00058	71369819	AL42	DISK HEAD PROTECTION Ø 32 PLASTIC
5	MLN01272		AL387	CERAMIC SPACER 36x12

[Dimensions in Inches (mm)]

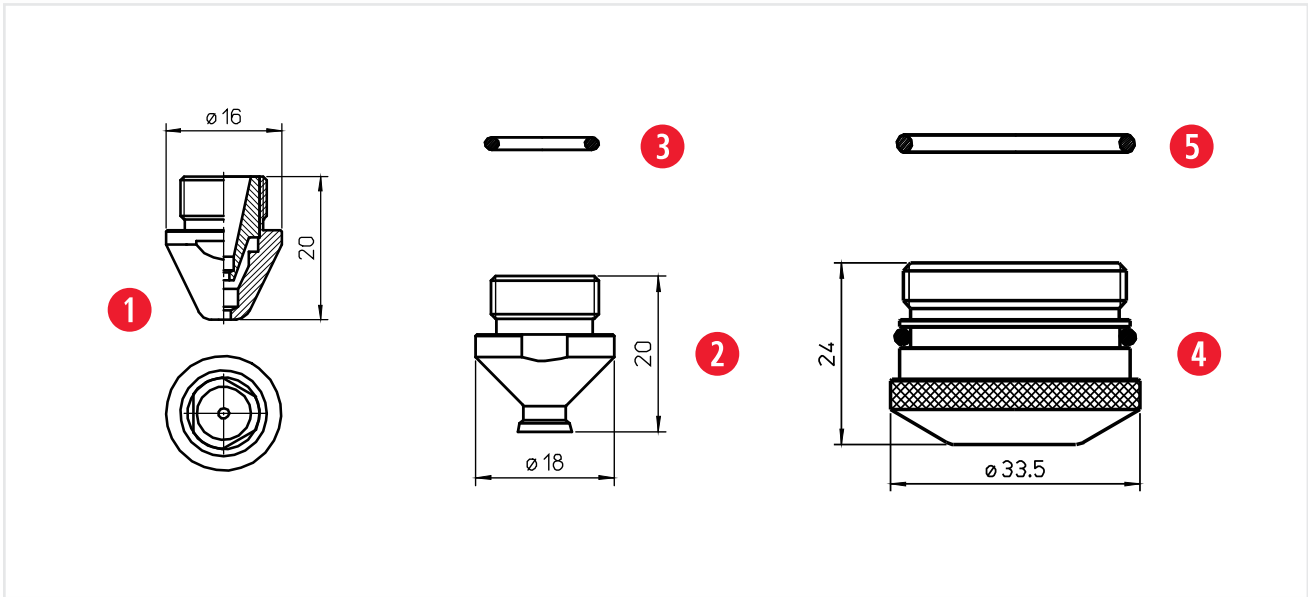

POS	MATE PART NUMBER	OEM CODE	ALTERNATE CODE	PART DESCRIPTION
1	MLN00013	1669864, 7134162	L390X	DOUBLE - 1.0MM NOZZLE CHROME
	MLN00307	71369811, 1669864, 7134162	L392X	DOUBLE - 1.2MM NOZZLE CHROME
	MLN00308	1669864, 7134162	L393X	DOUBLE - 1.4MM NOZZLE CHROME
	MLN00014	1669864, 7134162, 71369809	L391X	DOUBLE - 1.5MM NOZZLE CHROME
	MLN01532	1669864, 7134162	L780X	DOUBLE - 1.8MM NOZZLE CHROME
	MLN00015	1669864, 7134162, 71341680	L315X	DOUBLE - 2.0MM NOZZLE CHROME
	MLN00016	1669864, 7134162, 71341680	L316X	DOUBLE - 2.5MM NOZZLE CHROME
	MLN00309	1669864, 7134163	L317X	DOUBLE - 3.0MM NOZZLE CHROME
	MLN00596	1669864, 7134162	L768X	DOUBLE - 3.5MM NOZZLE CHROME
	MLN00513	1669864, 7134162	L319X	DOUBLE - 3.8MM NOZZLE CHROME
	MLN00399	1669795, 71341681	L318X	DOUBLE - 4.0MM NOZZLE CHROME
	2	MLN00522	71366090	L765X
MLN00619		71366090, 130266	L766X	DOUBLE - 1.4MM NOZZLE CHROME
MLN00028		71366090, 71341682	L324X	DOUBLE - 2.0MM NOZZLE CHROME
3	MLN00031	S-14, 71341683	AL93	O-RING FOR NOZZLE
4	MLN00033	71366452, 71341684, 6551148A	AL115X	OUTER NOZZLE CHROME
5	MLN00034	71366453	AL94	O-RING FOR NOZZLE OUTER

[Dimensions in Inches (mm)]

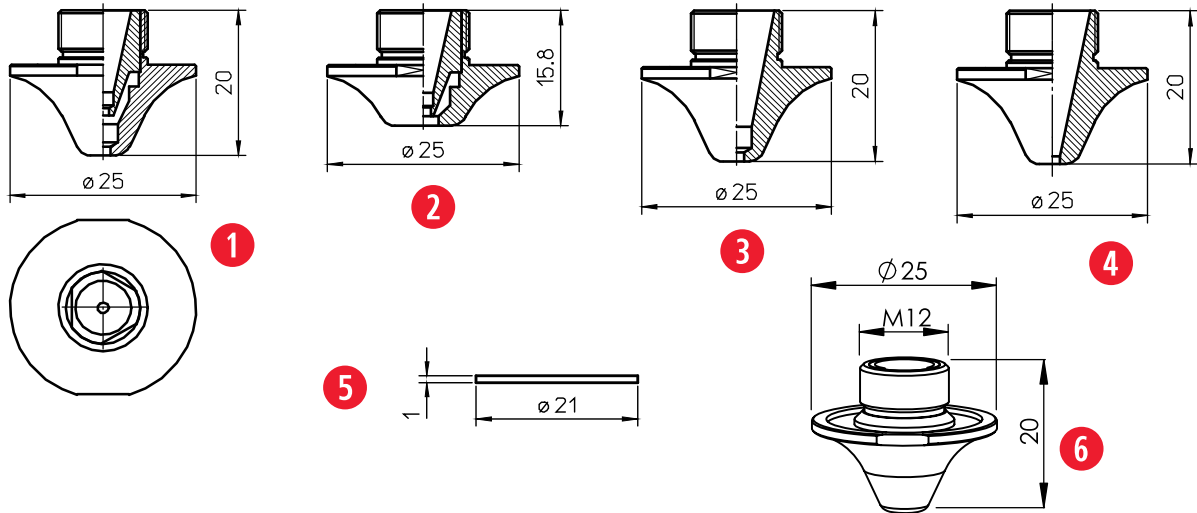

POS	MATE PART NUMBER	OEM CODE	ALTERNATE CODE	PART DESCRIPTION
1	MLN00452	1572361, 71369811	L585X	DOUBLE - 1.2MM NOZZLE CHROME
	MLN00453	71502038, 71369813, 71518550, 71341779	L586X	DOUBLE - 1.4MM NOZZLE CHROME
	MLN00930	1572361, 71518548, 1572380	L574X	DOUBLE - 1.7MM NOZZLE CHROME
	MLN00454	1572361, 71515392, 71369813	L587X	DOUBLE - 2.0MM NOZZLE CHROME
	MLN00586	71501059, 71515394, 71516789, 1576398	L584X	DOUBLE - 2.5MM NOZZLE CHROME
	MLN00455	1572361	L588X	DOUBLE - 3.0MM NOZZLE CHROME
	MLN00456	71515395, 71516790, 1576399, 71369817	L589X	DOUBLE - 4.0MM NOZZLE CHROME
	MLN00622		L1037X	DOUBLE - 4.0MM NOZZLE CHROME
	MLN00623	1572361	L583X	DOUBLE - 5.0MM NOZZLE CHROME
MLN00624		L569X	DOUBLE - 6.0MM NOZZLE CHROME	
2	MLN01485		L565X	DOUBLE - 4.0MM NOZZLE SHORT CHROME
	MLN01486		L567X	DOUBLE - 5.0MM NOZZLE SHORT CHROME
3	MLN00625	71369822, 1572362, 71563584	L590X	SINGLE - 0.8MM NOZZLE CHROME
	MLN00626	1572367A, 71563585	L591X	SINGLE - 1.0MM NOZZLE CHROME
	MLN00457	71369812	L592X	SINGLE - 1.2MM NOZZLE CHROME
	MLN00458	1572362, 71369813	L593X	SINGLE - 1.4MM NOZZLE CHROME
	MLN00929	1572362, 1572368B	L597X	SINGLE - 1.5MM NOZZLE CHROME
	MLN01098	1572362	L575X	SINGLE - 1.7MM NOZZLE CHROME
	MLN00459	71515392, 71369815	L594X	SINGLE - 2.0MM NOZZLE CHROME
	MLN01487		L572X	SINGLE - 2.5MM NOZZLE CHROME
	MLN00460	71515393, 1576112, 71369816	L595X	SINGLE - 3.0MM NOZZLE CHROME
MLN00461	1572362, 71515395, 71369815	L596X	SINGLE - 4.0MM NOZZLE CHROME	
4	MLN01068	71369822	L1027X	SINGLE - 0.8MM NOZZLE STRAIGHT TAPER CHROME
	MLN01069		L1028X	SINGLE - 1.0MM NOZZLE STRAIGHT TAPER CHROME
	MLN01070	71461028	L1029X	SINGLE - 1.2MM NOZZLE STRAIGHT TAPER CHROME
	MLN01071		L1030X	SINGLE - 1.4MM NOZZLE STRAIGHT TAPER CHROME
	MLN00928	71501056	L599X	SINGLE - 1.5MM NOZZLE STRAIGHT TAPER CHROME
	MLN01488		L1032X	SINGLE - 1.7MM NOZZLE STRAIGHT TAPER CHROME
	MLN00927	71501057	L598X	SINGLE - 2.0MM NOZZLE STRAIGHT TAPER CHROME
	MLN01489		L1033X	SINGLE - 2.3MM NOZZLE STRAIGHT TAPER CHROME
	MLN01072	71501058	L571X	SINGLE - 3.0MM NOZZLE STRAIGHT TAPER CHROME
5	MLN00059	71341614	AL1005	DISC HEAD PROTECTION Ø 21 PLASTIC
	MLN00060	71364816, 71341614	AL122	DISC HEAD PROTECTION Ø 21 VESPEL
6	MLN00588		L1026X	
	MLN00589	71502038	L1031X	

[Dimensions in Inches (mm)]

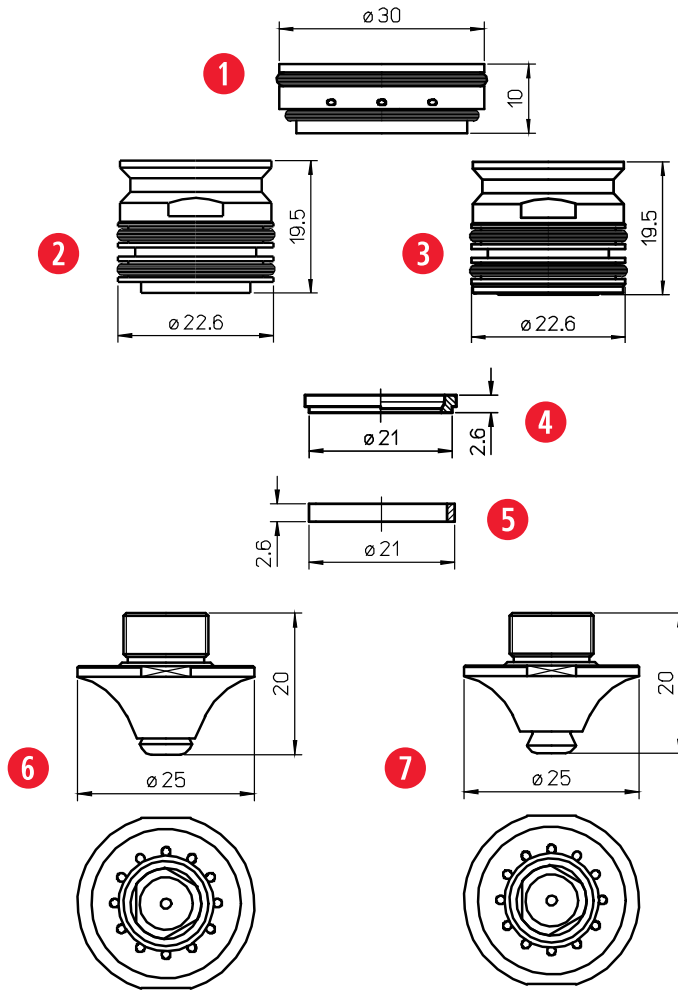

POS	MATE PART NUMBER	OEM CODE	ALTERNATE CODE	PART DESCRIPTION
1	MLN01490	71502026	AL340	INSULATOR FOR ADAPTOR - PTFE
2	MLN00630	71502036	AL248	NOZZLE ADAPTOR WITH 8 HOLES
3	MLN01491	71502036	AL348	NOZZLE ADAPTOR WITH 12 HOLES
	MLN00941 (NOT SHOWN)		AL268	O-RINGS FOR MLN00630
4	MLN00942		AL233	COLLAR RIGID VERSION FOR WACS - PTFE
5	MLN00583	71515853	AL234	COLLAR FOR WACS PTFE
6	MLN00943	71461026	L1155X	DOUBLE - 2.5MM WACS NOZZLE WITH HOLES
	MLN00944	71461158	L1159X	DOUBLE - 4.0MM NOZZLE WITH HOLES CHROME
7	MLN00945	71502055	L1041X	DOUBLE - 1.4MM NOZZLE WITH HOLES CHROME
	MLN00946	71518545	L1043X	DOUBLE - 1.7MM NOZZLE WITH HOLES CHROME
	MLN00947		L1044X	DOUBLE - 2.0MM NOZZLE WITH HOLES CHROME
	MLN00584	71502039	L1045X	DOUBLE - 2.5MM NOZZLE WITH HOLES CHROME
	MLN00585	71502040	L1049X	DOUBLE - 4.0MM NOZZLE WITH HOLES CHROME
	MLN00948	71502057	L1050X	DOUBLE - 5.0MM NOZZLE WITH HOLES CHROME

[Dimensions in Inches (mm)]

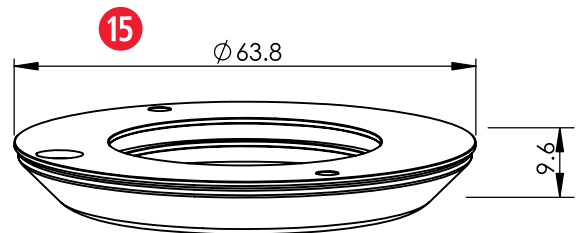
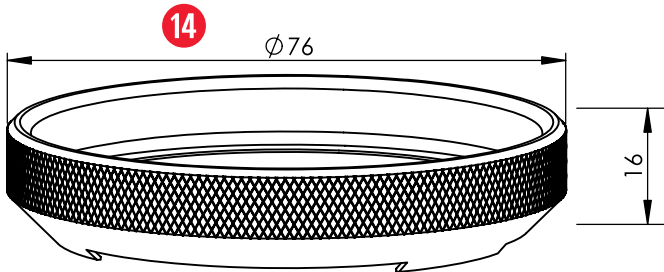
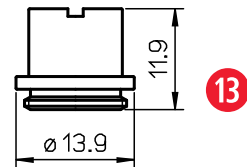
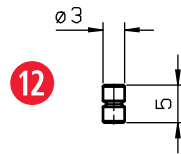
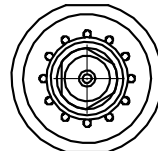
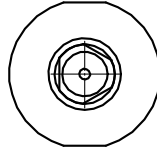
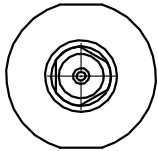
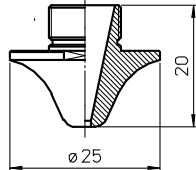
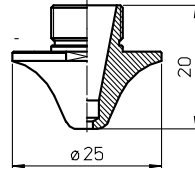
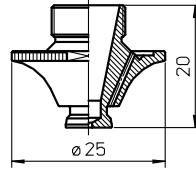
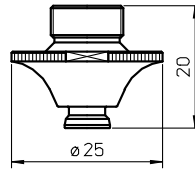
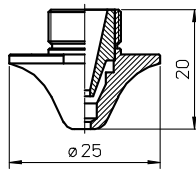
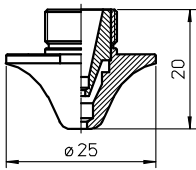
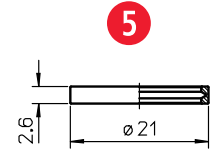
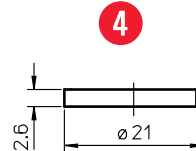
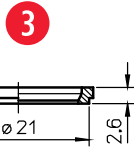
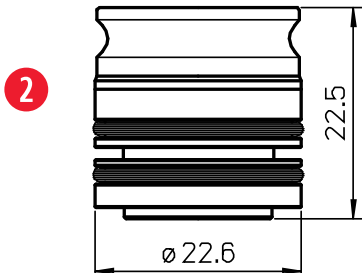
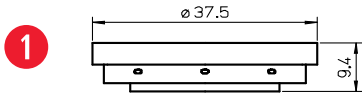
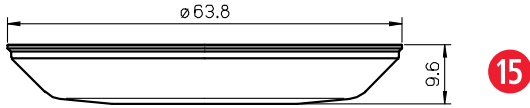
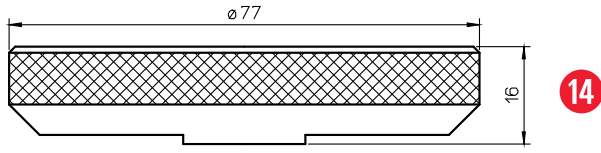

[Dimensions in Inches (mm)]



POS	MATE PART NUMBER	OEM CODE	ALTERNATE CODE	PART DESCRIPTION
1	MLN01175	71561666, 7973497, 71712349	AL372	HOLDER - PTFE
2	MLN01092	71712350 , 7973459	AL360	NOZZLE ADAPTOR WITH HOLES
	MLN01182	71712350 , 7973459	AL360/AM	NOZZLE ADAPTOR WITH HOLES and INNER
	MLN02004		AL397	O-RING KIT FOR ADAPTOR
3	MLN00942		AL233	COLLAR RIGID VERSION FOR WACS - PTFE
4	MLN00583	71515853	AL234	COLLAR FOR WACS - PTFE
5	MLN01166	71712340	AL361	COLLAR WITH GROOVE - PTFE
6	MLN01063	71518550, 71461029, 71502038	L1401X	DOUBLE - 1.4E NOZZLE ECO CUT CHROME
	MLN01064	71516789, 71501059	L1403X	DOUBLE - 2.5MM NOZZLE ECP CUT CHROME
	MLN01254		L1404X	DOUBLE - 3.0MM NOZZLE ECO CUT CHROME
	MLN01134	71369817, 71516790, 71501060	L1405X	DOUBLE - 4.0MM NOZZLE ECO CUT CHROME
7	MLN01161	71501690, 71501093, 71572667	L1406X	DOUBLE - 4.MM NOZZLE AL CHROME
8	MLN01162	71712337	L1352X	DOUBLE - 1.4MM NOZZLE WACS CHROME
	MLN01492		L1352X/TG	DOUBLE - 1.4MM NOZZLE WACS WITH COLLAR CHROME
	MLN01163	71502056, 71712338	L1353X	DOUBLE - 1.7MM NOZZLE WACS CHROME
	MLN01493	71398307	L1353X/TG	DOUBLE - 1.7MM NOZZLE WACS WITH COLLAR CHROME
	MLN01176	71512338, 71502086	L1354X	DOUBLE - 2.0MM NOZZLE WACS CHROME
	MLN01494		L1354X/TG	DOUBLE - 2.0MM NOZZLE WACS WITH COLLAR CHROME
	MLN01165	71712335	L1355X	DOUBLE - 2.5MM NOZZLE WACS CHROME
	MLN01255	71712335	L1355X/TG	DOUBLE - 2.5MM NOZZLE WACS WITH COLLAR CHROME
	MLN01169	71712336 , 71461158	L1359X	DOUBLE - 4.0MM NOZZLE WACS CHROME
	MLN01495		L1359X/TG	DOUBLE - 4.0MM NOZZLE WACS WITH COLLAR CHROME
	MLN01496	71712339, 71502057, 71398316	L1360X	DOUBLE - 5.0MM NOZZLE WACS CHROME
	MLN01497		L1360X/TG	DOUBLE - 5.0MM NOZZLE WACS WITH COLLAR CHROME
9	MLN01167	71712336, 71468158	L1568X	SINGLE - 1.2MM NOZZLE WACS CHROME
10	MLN01062	71502037, 71461028	L1407X	SINGLE - 1.2MM NOZZLE ECO CUT CHROME
11	MLN01168		L1410X	SINGLE - 1.4MM NOZZLE ECO CUT CHROME
	MLN01533	71501056 , 71712720	L1411X	SINGLE - 1.5MM NOZZLE ECO CUT CHROME
	MLN01534	71501057, 71555124	L1412X	SINGLE - 2.0MM NOZZLE ECO CUT CHROME
	MLN01170	71516788, 71501058	L1413X	SINGLE - 3.0MM NOZZLE ECO CUT CHROME
12	MLN01174	71712344	AL359	LOCATING PIN
13	MLN01154	71716438 , 71798350	AL392	INNER FOR ADAPTOR
14	MLN01498	71712341	AL455XH	NUT KIT (NUT, O-RING - LOCATING PIN
15	MLN01499	71712342	AL456XH	COVER KIT (COVER, S25 O-RING, A38 O-RING)

[Dimensions in Inches (mm)]

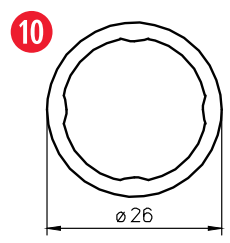
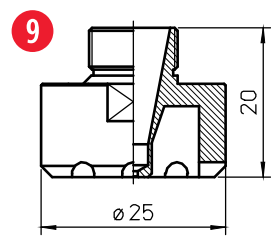
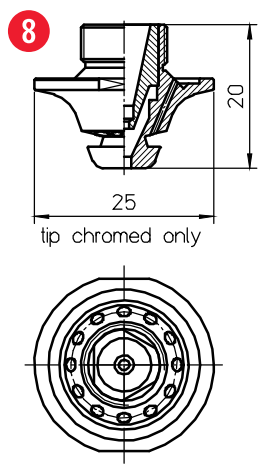
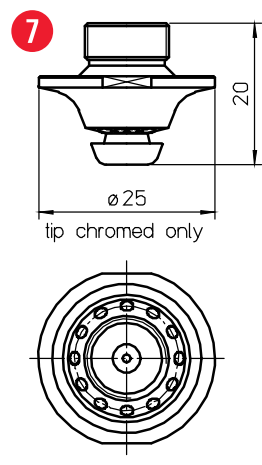
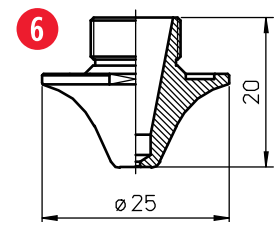
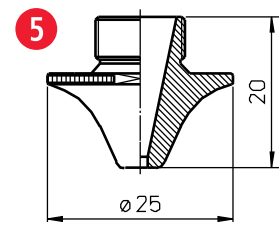
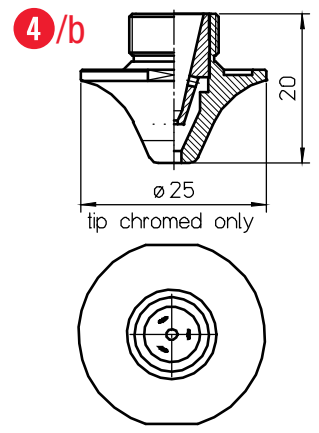
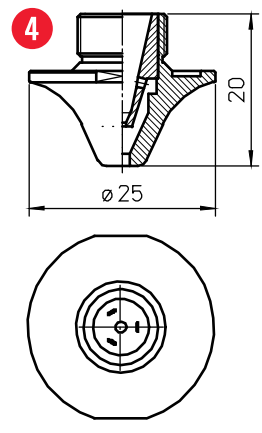
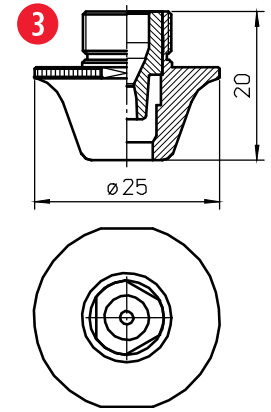
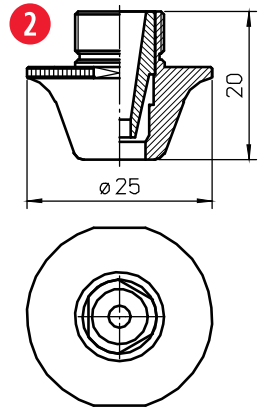
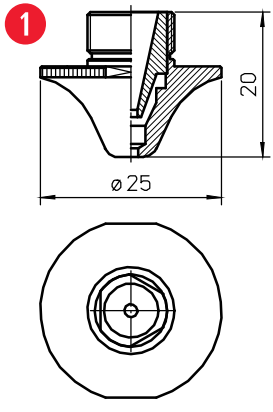

[Dimensions in Inches (mm)]



POS	MATE PART NUMBER	OEM CODE	ALTERNATE CODE	PART DESCRIPTION
1	MLN01137	71501059	L1415XH	DOUBLE - 2.5MM NOZZLE SPECIAL CLEAN CUT CHROME
	MLN01093	71341728 - 71555121	L1416XH	DOUBLE - 4.0MM NOZZLE SPECIAL CLEAN CUT CHROME
2	MLN01500		L1417XH	DOUBLE 5.0MM NOZZLE SPECIAL CLEAN CUT CHROME
	MLN01501		L1418XH	DOUBLE - 6.0MM NOZZLE SPECIAL CLEAN CUT CHROME
	MLN01160	71341729 - 71712721	L1419XH	DOUBLE - 7.0MM NOZZLE SPECIAL CLEAN CUT CHROME
	MLN01502	71501092	L1425X	DOUBLE - 7.0MM NOZZLE AL CLEAN CUT CHROME
3	MLN01173	71712692, 71341719, 9010191	L1420X	DOUBLE - 7.0MM NOZZLE SILKY CUT CHROME
4	MLN01135	71570022	L1645X	DOUBLE - 2.0MM NOZZLE F CHROME
	MLN01336	71516789	L1646X	DOUBLE - 2.5MM NOZZLE F CHROME
	MLN01503	71516990	L1649X	DOUBLE - 4.0MM NOZZLE F CHROME
4/b	MLN01504		L1644XH	DOUBLE - 1.5MM NOZZLE F CHROME
	MLN01505	71570022	L1645XH	DOUBLE - 2.0MM NOZZLE F CHROME
5	MLN01164		L1421XH	SINGLE - 1.5MM NOZZLE SPECIAL CLEAN CUT CHROME
	MLN01171	71502043	L1422XH	SINGLE - 2.0MM NOZZLE SPECIAL CLEAN CUT CHROME
	MLN01159		L1424XH	SINGLE - 2.5MM NOZZLE SPECIAL CLEAN CUT CHROME
	MLN01172	71502044	L1423XH	SINGLE - 3.0MM NOZZLE SPECIAL CLEAN CUT CHROME
6	MLN01130		L1560X	SINGLE - 0.8MM NOZZLE FE CHROME
	MLN01131	71570030, 71570021	L1561X	SINGLE - 1.0MM NOZZLE FE CHROME
	MLN01132	71570020, 9010393	L1562X	SINGLE - 1.2MM NOZZLE FE CHROME
	MLN01133		L1563X	SINGLE - 1.4MM NOZZLE FE CHROME
7	MLN01506		L1653XH	SINGLE - 0.8MM NOZZLE FE FIBER CHROME
	MLN01507		L1653XH/TG	SINGLE - 0.8MM NOZZLE FE FIBER WITH COLLAR CHROME
	MLN01155	71570030	L1654XH	SINGLE - 1.0MM NOZZLE FE FIBER CHROME
	MLN01245	71570030	L1654XH/TG	SINGLE- 1.0MM NOZZLE FE FIBER WITH COLLAR CHROME
	MLN01156	71570020, 71570023	L1655XH	SINGLE - 1.2MM NOZZLE FE FIBER CHROME
	MLN01246	71570023	L1655XH/TG	SINGLE - 1.2MM NOZZLE FE FIBER WITH COLLAR CHROME
	MLN01250		L1656XH	SINGLE - 1.4MM NOZZLE FE FIBER CHROME
	MLN01247		L1656XH/TG	SINGLE - 1.4MM NOZZLE FE FIBER WITH COLLAR CHROME
	MLN01251		L1657XH	SINGLE - 1.7MM NOZZLE FE FIBER CHROME
	MLN01248		L1657XH/TG	SINGLE - 1.8MM NOZZLE FE FIBER WITH COLLAR CHROME
	MLN01252		L1658XH	SINGLE - 2.0MM NOZZLE FE FIBER CHROME
	MLN01249		L1658XH/TG	SINGLE - 2.0MM NOZZLE FE FIBER WITH COLLAR CHROME
8	MLN01508	71568227	L1900XH	DOUBLE - 1.2MM NOZZLE FE FIBER CHROME
	MLN01509		L1901XH	DOUBLE - 1.5MM NOZZLE FE FIBER CHROME
9	MLN01256		L1333	SINGLE - 2.0MM NOZZLE
10	MLN01253		AL403	COLLAR - PTFE

[Dimensions in Inches (mm)]

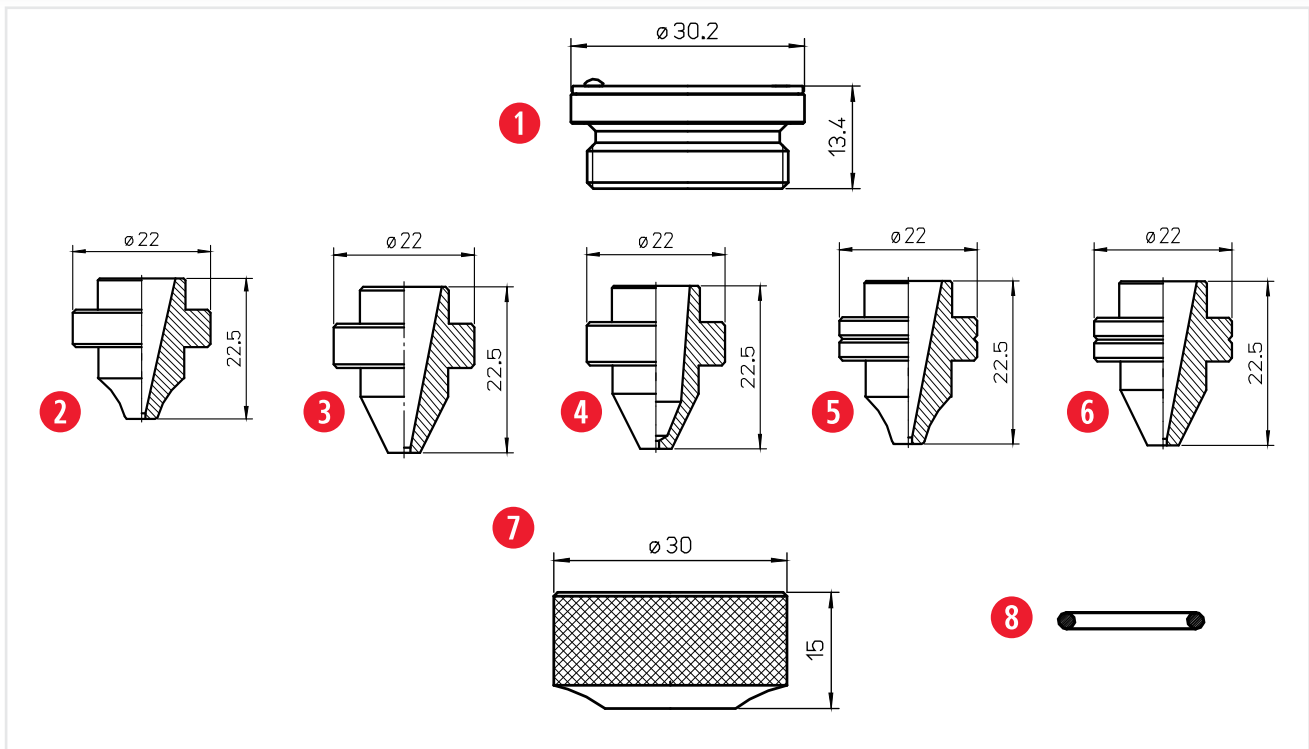

POS	MATE PART NUMBER	OEM CODE	ALTERNATE CODE	PART DESCRIPTION
1	MLN01061	P0594-860-00001-7180001	AL267	HOLDER HOLDER IT HP2" MZP/MEL
2	MLN01679	71800016A0, BQ933D283H01	L1126	SINGLE - 1.0MM NOZZLE WITH RADIUS NO GROOVE
3	MLN00951	71800018, BQ943D157H01	L1134	SINGLE - 1.5MM NOZZLE
	MLN02008		L1131	SINGLE - 1.7MM NOZZLE
	MLN00952	71800019, BQ943D157H02	L1135	SINGLE - 2.0MM NOZZLE
	MLN00953	71800020, BQ943D157H03	L1136	SINGLE - 2.5MM NOZZLE
	MLN00954	71800021, BQ943D157H04	L1137	SINGLE - 3.0MM NOZZLE
	MLN00955	71800022, BQ943D596H01	L1138	SINGLE - 3.5MM NOZZLE
	MLN01678		L1139	SINGLE - 4.0MM NOZZLE
	MLN02009	71800109, BQ943D714H01	L1140X	SINGLE - 4.0MM NOZZLE FOR FOCUS POINT CHROME
4	MLN00956	71800016, BQ943D897H01	L1125	SINGLE - 1.0MM NOZZLE HV
	MLN00957	W18Q93309101	L1128	SINGLE - 2.5MM NOZZLE HV
	MLN00958	W18Q93309102	L1129	SINGLE - 3.0MM NOZZLE HV
5	MLN00959	71800017, BQ943D269H01	L1130	SINGLE - 1.2MM NOZZLE HV WITH RADIUS
6	MLN00960	W18Q93302701	L1132	SINGLE - 1.7MM NOZZLE HV
7	MLN00961	71800026, BQ933D94H01	AL269	NOZZLE NUT SHORT
8	MLN01306	W290, 71800107	AL388	O-RING

[Dimensions in Inches (mm)]

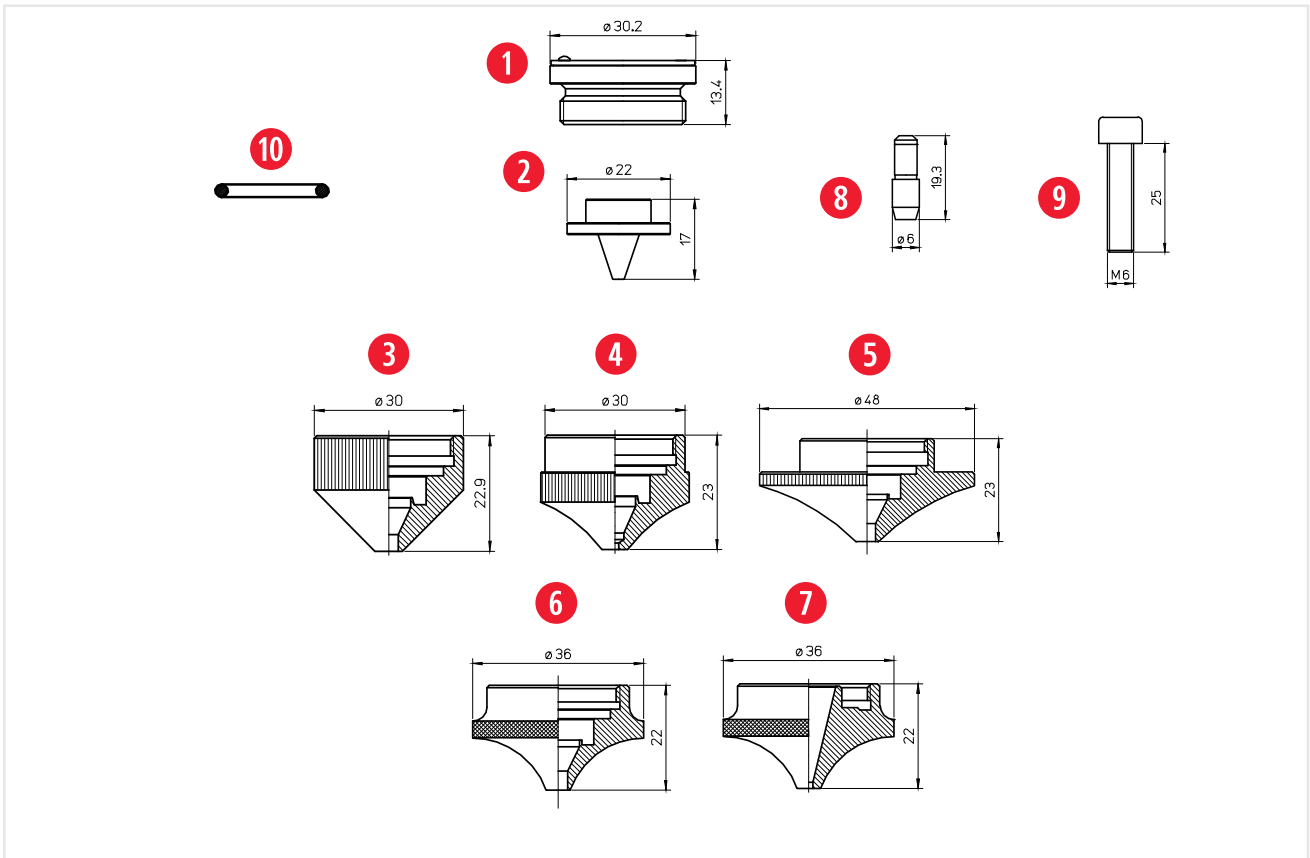

POS	MATE PART NUMBER	OEM CODE	ALTERNATE CODE	PART DESCRIPTION
1	MLN01061	P0594-860-00001 - 71800010 - PHX-INS	AL267	NOZZLE HOLDER IT HP2" MZP/MEL
2	MLN00949	71800023 - BQ943D156H01/W270-1.5	L1119	SINGLE - 1.5MM NOZZLE INNER WITH 8 HOLES
	MLN00950	71800024 - BQ943D156H03	L1123	SINGLE - 1.5MM NOZZLE INNER WITH 24 HOLES
	MLN01510	W270.2	L1120	SINGLE - 2.0MM NOZZLE INNER WITH 8 HOLES
	MLN01511	W515.2	L1124	SINGLE - 2.0MM NOZZLE INNER WITH 24 HOLES
3	MLN00815	71800027, BQ933D221H04 P0593-860-00001	AL238	SHIELD CAP SHORT
	MLN01512		AL238X	SHIELD CAP SHORT CHROME
4	MLN01029		AL302	SINGLE - 1.7MM NOZZLE OUTER
	MLN01030		AL303	SINGLE - 2.0MM NOZZLE OUTER
	MLN01031		AL304	SINGLE - 2.5MM NOZZLE OUTER
	MLN01032		AL305	SINGLE - 3.0MM NOZZLE OUTER
	MLN01033		AL306	SINGLE - 4.0MM NOZZLE OUTER
5	MLN01034	BQ933D044H01, 71800101 W18Q93304401	AL266	OUTER NOZZLE HIGH SPEED PIERCE
6	MLN01513	71802197 , BQ933D044H01	AL270	OUTER NOZZLE
7	MLN01514	7180015400 , BQ023D020H01	L1262	SINGLE - 1.7MM NOZZLE HIGH SPEED PIERCE
8	MLN01515	71800009 , P921K000P25 JPZA5-6	AL345	SAFETY PIN
9	MLN01516	71800008 , L2490A005	AL346	SAFETY SCREW
10	MLN01306	W290, 71800107	AL388	O-RING

[Dimensions in Inches (mm)]

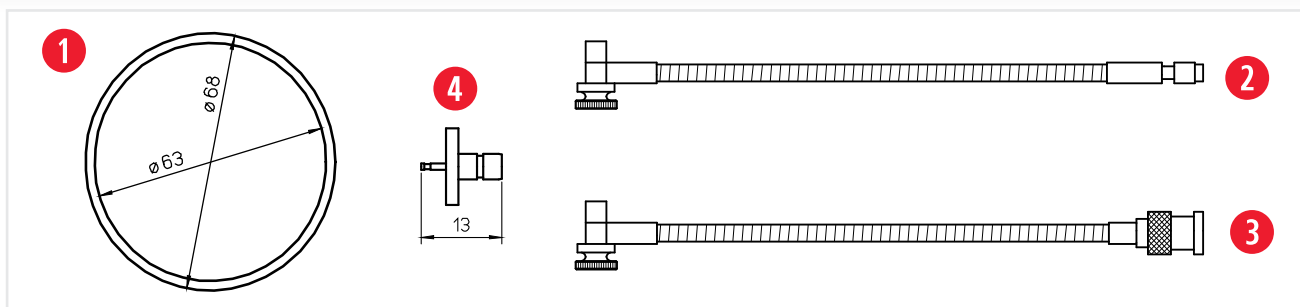

POS	MATE PART NUMBER	OEM CODE	ALTERNATE CODE	PART DESCRIPTION
1	MLN00082	AL56	71109513, 71109680	GASKET FOR SENSOR HEAD - PTFE
2	MLN00633	AL200	71341630, 71398293, 71232028, 71400517	CONNECTING CABLE HS-5 305MM SHORT 12"
3	MLN00963	AL260	71398965, 658393102	CONNECTING CABLE HS-15 FO 315MM 12"
4	MLN01100	AL263	71398095	SENSOR CABLE CONNECTOR, PANEL MOUNT

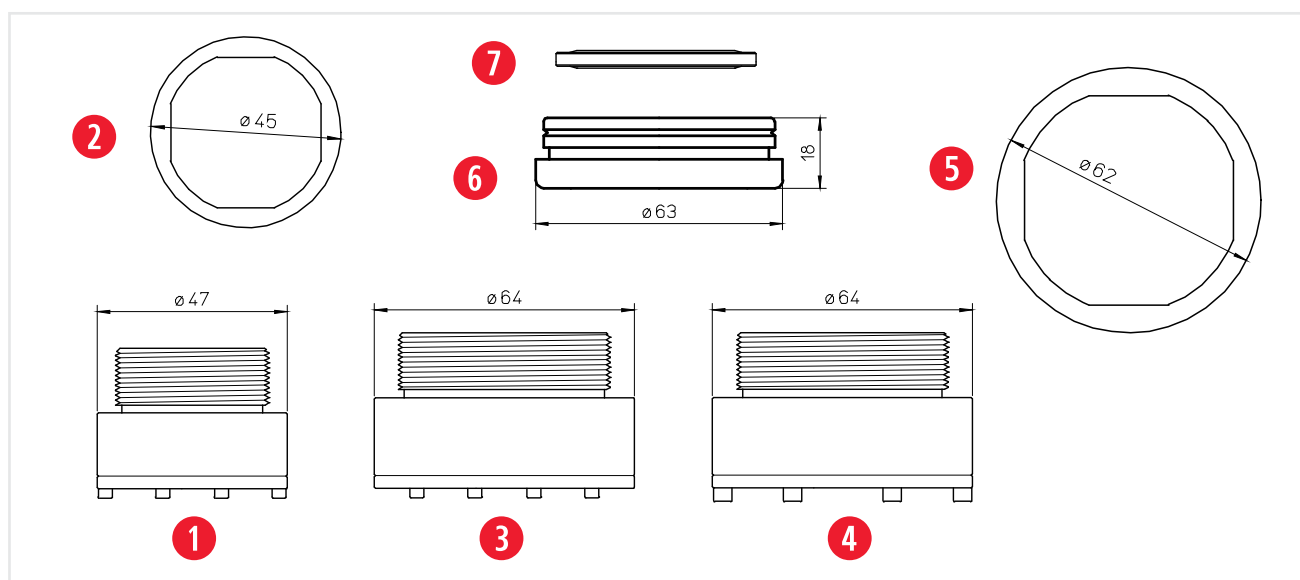

POS	MATE PART NUMBER	OEM CODE	ALTERNATE CODE	PART DESCRIPTION
1	MLN00550	71591228	A100	PULSAR/APELIO MOUNT FOR LENS Ø 1.5 BLACK
2	MLN00083	71360261, 71512355, 71109864	AL52	AMADA® GASKET PTFE - LENS HOUSING Ø1.5
3	MLN00593	71366182, 71368467	A105	GEMINI MOUNT FOR LENS Ø 2.0 BLACK
4	MLN00500		A107	GEMINI MOUNT FOR LENS Ø1.5 F.O. ALUMINIUM
5	MLN00502	71361393, 71109695	AL149	AMADA® GASKET PTFE - LENS HOUSING Ø2.0
6	MLN00632		A109	FONT MOUNT FOR LENS FL 5.0"
	MLN00631		A112	FONT MOUNT FOR LENS FL 7.5"
7	MLN00962	71501071	L1262	AMADA® GASKET FOR LENS FO NT

[Dimensions in Inches (mm)]



POS	MATE PART NUMBER	OEM CODE	ALTERNATE CODE	PART DESCRIPTION
1	MLN01108			PULSAR/APELIO TWIST MOUNT FOR LENS 1.5MM BLACK
2	MLN01109			FONT TWIST MOUNT FOR LENS FL 5.0"
3	MLN01110			FONT TWIST MOUNT FOR LENS FL 7.5"
4	MLN01111			GEMINI TWIST MOUNT FOR LENS 1.5"
5	MLN01112			GEMINI TWIST MOUNT FOR LENS 2.0"
6	MLN01113			F1 TWIST MOUNT 2" DIA X 7.5" FL
7	MLN01114			F1 TWIST MOUNT 2" DIA X 5.0" FL

[Dimensions in Inches (mm)]

PERFORMAX - STANDARD ABSORPTION LENSES

MATE PART NUMBER	OEM CODE	TYPE	DIAMETER	FOCAL LENGTH	EDGE THICKNESS
MLL00028	81140305, 561067, 561067	PLANO CONVEX	1.1"(27.9mm)	5.0" (127mm)	0.160"(4.0mm)
MLL00020	81140225, 60990	PLANO CONVEX	1.5"(38.1mm)	5.0"(127mm)	0.118(3.0mm)
MLL00010	60770	PLANO CONVEX	1.5"(38.1mm)	5.0"(127mm)	0.236"(5.9mm)
MLL00011	81140399, 60784	PLANO CONVEX	1.5"(38.1mm)	7.5"(190.5mm)	0.244"(6.2mm)
MLL00015	71109683, 8114022, 60884	PLANO CONVEX	1.5"(38.1mm)	3.75"(95.2mm)	.300"(7.6mm)
MLL00016	578662, 71109680, 71519408, 7973109, 71501072, 63670	PLANO CONVEX	1.5"(38.1mm)	5.0"(38.1mm)	.300"(7.6mm)
MLL00017	7973110, 464497, 71109681, 8140400, 62649	PLANO CONVEX	1.5"(38.1mm)	7.5"(190.5mm)	.300"(7.6mm)
MLL00018	7155520, 232771, 81140156, 71710030, 60698, 61405	PLANO CONVEX	2.0"(50.8mm)	7.5"(190.5mm)	.380"(9.65mm)
MLL00027	71710059, 81140307, 61019	PLANO CONVEX	2.0"(50.8mm)	5.0"(127.0mm)	.380"(9.65mm)

PERFORMAX - STANDARD ABSORPTION MOUNTED LENSES

MATE PART NUMBER	OEM CODE	TYPE	DIAMETER	FOCAL LENGTH	EDGE THICKNESS
MLL00031	81140306, 74722622	PLANO CONVEX	1.5"(38.1mm)	5.0"(38.1mm)	.300"(7.6mm)
MLL00032	81140400	PLANO CONVEX	1.5"(38.1mm)	7.5"(190.5mm)	.300"(7.6mm)

PEAK - LOW ABSORPTION LENSES

MATE PART NUMBER	OEM CODE	TYPE	DIAMETER	FOCAL LENGTH	EDGE THICKNESS
MLP00016	406294, 055491	PLANO CONVEX	1.5" (38.1mm)	5.0" (127mm)	.300" (7.6mm)
MLP00017	055492, 702232	PLANO CONVEX	1.5" (38.1mm)	7.5" (190mm)	.300" (7.6mm)
MLP00027	206326	PLANO CONVEX	2.0" (50.8mm)	5.0" (127mm)	.380" (9.6mm)
MLP00018	7155520, 81140156	PLANO CONVEX	2.0" (50.8mm)	7.5" (190.5mm)	.380" (9.6mm)

BLACK MAGIC- LOW ABSORPTION LENSES

MATE PART NUMBER	OEM CODE	TYPE	DIAMETER	FOCAL LENGTH	EDGE THICKNESS
MLB00016	578662, 71109680, 71519408, 7973109, 71501072, 63670	PLANO CONVEX	1.5"(38.1mm)	5.0"(127.0mm)	.300"(7.6mm)
MLB00017	7973110, 464497, 71109681, 8140400, 62649	PLANO CONVEX	1.5"(38.1mm)	7.5"(190.5mm)	.300"(7.6mm)
MLB00018	7155520, 232771, 81140156, 71710030, 60698, 61405	PLANO CONVEX	2.0"(50.8mm)	7.5"(190.5mm)	.380"(9.65mm)
MLB00027	71710059, 81140307	PLANO CONVEX	2.0"(50.8mm)	5.0"(127mm)	.380"(9.65mm)

FIBERMAX - FIBER LASER LENSES

MATE PART NUMBER	OEM CODE	TYPE	DIAMETER	FOCAL LENGTH	EDGE THICKNESS
MLF00001	71570005, 71570036, 7710371, 29510125	FUSED SILICA	50.8mm	180mm	3.0mm
MLF00002	71570007	FUSED SILICA	38.1mm	220mm	3.3mm
MLF00003	7157035, 7710370, 7157006	FUSED SILICA	50.8mm	150mm	11.6mm
MLF00012	7710238, 7710236, CC33061412, 23425	FUSED SILICA	50.8mm	190mm	11.5mm

FIBERSHIELD - FIBER LASER PROTECTIVE WINDOWS

MATE PART NUMBER	OEM CODE	TYPE	DIAMETER	EDGE THICKNESS
MLW00001	462746, 71570028	FUSED SILICA	12.0mm	2.0mm
MLW00010		FUSED SILICA	50.8mm	6.3mm
MLW00011	71570026, 5016125 octagon	FUSED SILICA	33.0mm	1.5mm
MLW00012	10045746, 500697866.1	FUSED SILICA	19.0mm	6.3mm
MLW00013		FUSED SILICA	19.0mm	3.0mm
MLW00021		FUSED SILICA	38.1mm	6.3mm
MLW00026	71571308, 71598028	FUSED SILICA	45.0mm	3.0mm

OPTICS CARE

MATE PART NUMBER	DESCRIPTION
MLN00570	1.5" Polarizer Filter
MLN01105	Cleaning Holder w/ 1.5" Polarizer Filter
MLN01106	Cleaning Holder w/ 2.0" Polarizer Filter
MLN01104	Wet Cleaning Wipes - 24 Pack
MLN01996	Optical Cleaning Fluid - Spray
MLN01997	Lens Cleaning Paper - 50 Sheets
MLN01998	4x4 Polyester Wipes - 100 Pack Texwipes
MLN02000	Lens Cleaning Swabs - 25 Pack Knit Polyester Tip
MLN01483	Lens / Mirror Cleaning Base
MLN00582	Lensmate Cleaning Paper - Booklet 4x6 Sheets

[Dimensions in Inches (mm)]



SHOP 24/7 AT shop.mate.com

Search

Cart
0 item(s) in cart total: \$0.00
[View](#)
Hello, Guest! [Login](#)

Category

- Laser Technologies
 - CO2 Lenses & Mirrors
 - Fiber Lenses & Windows
 - CO2 & Fiber Laser Consumables
- Press Brake Tooling
 - Blaw-Tong Style
 - European Precision Style
 - Wia Trumpf Style
 - CleanDend™
 - Press Brake Accessories

Home > Laser Technologies

Laser Technologies

Mate offers a complete range of state-of-the-art CO2 and Fiber Laser optics and consumables to meet virtually any laser need. We offer over 2,000 competitively priced parts including lenses, windows, nozzles, cables and more. Our product line includes:

CO2 Lasers:

- Performax™, Peak™ and Black Magic™ to meet a wide variety of performance needs.
- Trubeam™ mirrors that offer maximum reflectivity and durability for continuous service life.

Fiber Lasers:

- Fibermax™ lenses
- Fibershield™ windows

Consumables

- FLOWMASTER™ Nozzles that provide superior cutting control for improved cut quality
- FLOWMASTER™ Accessories
- LENSMAATE™ Maintenance Supplies

Available for all popular CO2 laser machines. Mate CO2 laser products are backed by our 100% satisfaction guarantee.

SUB-CATEGORIES

- CO2 Lenses & Mirrors
- Fiber Lenses & Windows
- CO2 & Fiber Laser Consumables**

Mate Precision Tooling is not affiliated with any named original equipment manufacturer. All names, part numbers and trademarks are the property of their respective owners and are used for identification purposes only. All products in this catalog are made for and/or by Mate Precision Tooling.

1295 Lund Boulevard • Anoka, Minnesota 55303 • USA
 (763) 421-0230 • (800) 328-6492
 En Español: +1 (763) 570-3700
mate.com

Copyright 2017 Mate Precision Tooling. All Rights Reserved.

Wide Selection for all OEMs

- CO₂ Lenses
- Fiber Lenses
- Consumables

Purchase orders and all major credit cards accepted.



shop.mate.com

[Dimensions in Inches (mm)]





MATE PRECISION TECHNOLOGIES GLOBAL COVERAGE

WORLDWIDE HEADQUARTERS:

1295 Lund Boulevard, Anoka, Minnesota 55303 USA
Tel +1.763.421.0230 mate.com

orders@mate.com